

REQUEST FOR COMMITTEE ACTION

HENDERSON COUNTY

TECHNICAL REVIEW COMMITTEE

MEETING: December 17, 2019

SUBJECT: Major Site Plan Review JSMG Investments LLC Office/Warehousing

PRESENTER: Toby Linville

ATTACHMENTS: Staff Report

SUMMARY OF REQUEST: Office Use

Suggested Motion: I move that the TRC approve/deny the major site plan for JSMG Investments LLC Office/Warehousing



Henderson County, North Carolina Code Enforcement Services

1. Committee Request

- 1.1. **Applicant:** JSMC Investments LLC
- 1.2. **Request:** Major Site Plan Approval
- 1.3. **PIN:** 9652402383, 9652406458, 9652404478, 9652403528, 9652401419
- 1.4. **Size:** 5.13 acres +/-
- 1.5. **Location:** The subject area is located off US Hwy 25 at 6034 Asheville Hwy
- 1.6. **Supplemental Requirements:**

SR 6.9 Office: Professional

- (1) Site Plan. Major *Site Plan* required in accordance with §42-331 (Major Site Plan Review).
- (2) Lighting. *Adequate lighting* shall be placed in areas used for vehicular/pedestrian access including, but not limited to: stairs, sidewalks, crosswalks, intersections, or changes in grade. *Lighting mitigation* required.

SR 9.15. Warehousing and Storage (Excluding Warehousing of Hazardous Substances)

- (1) Site Plan. Major *Site Plan* required in accordance with §42-331 (Major Site Plan Review).
- (2) Lighting. *Adequate lighting* shall be placed in areas used for vehicular/pedestrian access including, but not limited to: stairs, sidewalks, crosswalks, intersections, or changes in grade. *Lighting mitigation* required.
- (3) Dust Reduction. Unpaved *roads, travelways* and/or parking areas shall be treated to prevent dust from adverse effects to adjacent properties.

Map A: Aerial Photo/Pictometry

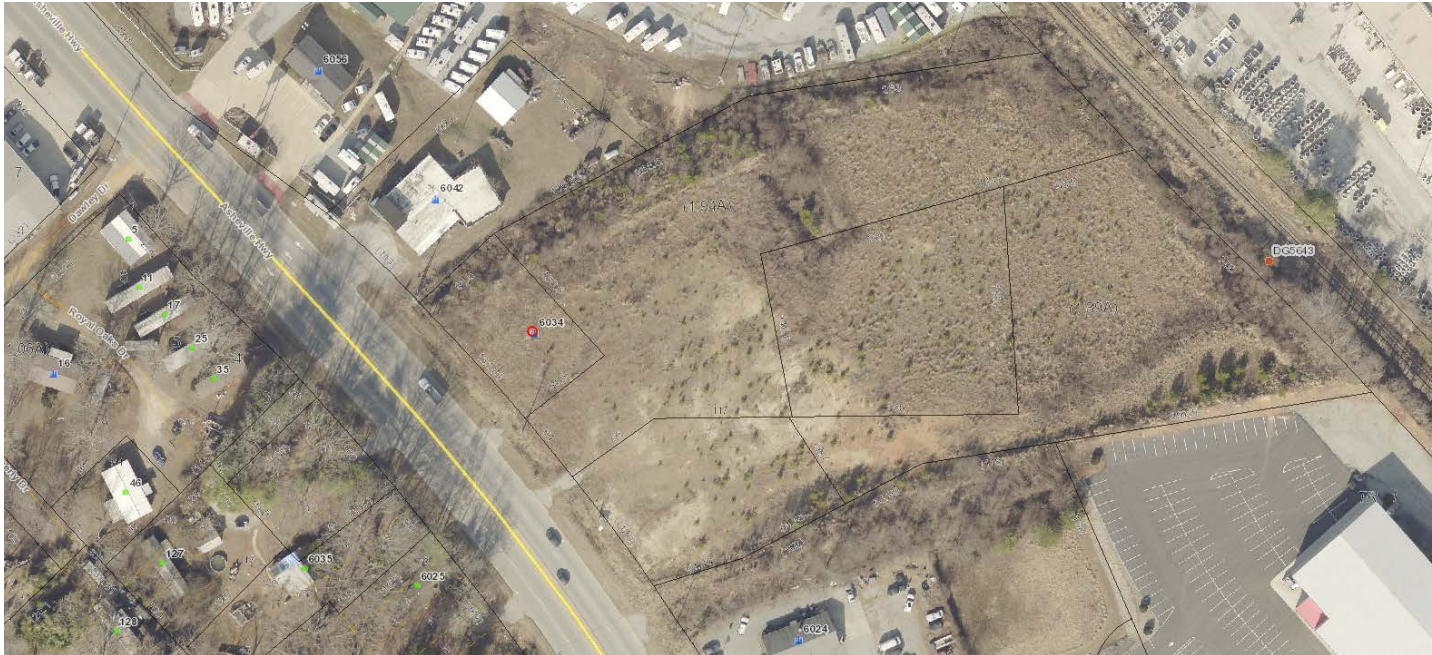

Map C: CCP Future Land Use Map

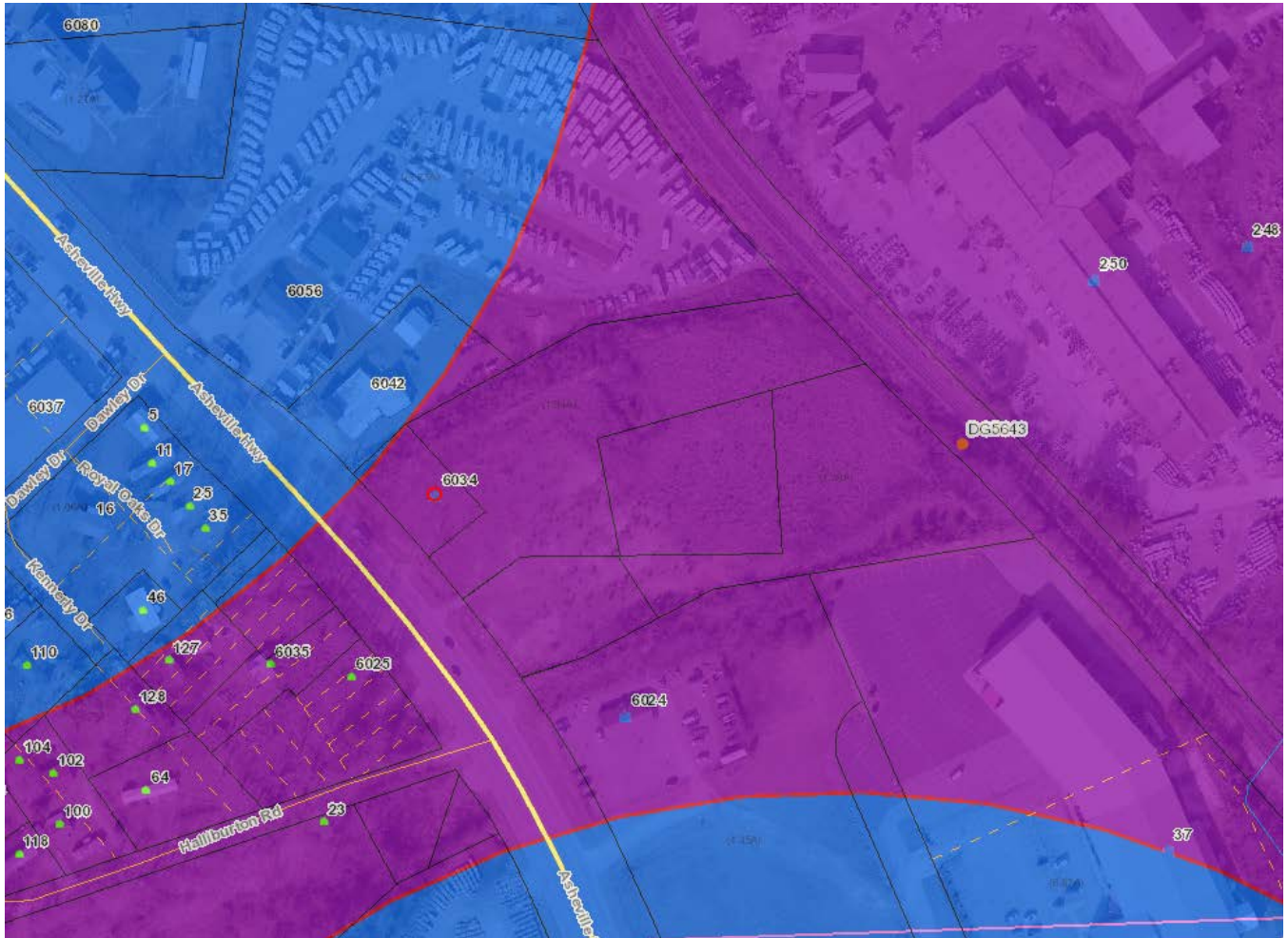

6. Staff Comments

The 2020 CCP: The CCP Future Land Use Map places the Subject Area in the Industrial Area. The text and map of the 2020 CCP suggest that the Subject Area would be more suitable for the following:

The purpose of the Industrial District (I) is to foster orderly growth where the *principal use* of land is a mixture of industrial and heavy commercial. The intent of this district is to allow for *industrial* and heavy *commercial development* consistent with the recommendations of the *Comprehensive Plan*. In accordance with the *Comprehensive Plan*, the district will allow for and provide *industrial* and heavy *commercial development* that: (1) is compatible with adjacent development and the surrounding community; (2) will minimize conflict between land *uses*; and (3) is sensitive to its impact on surrounding land *uses* and the environment (natural and man-made).

7. Staff Recommendations

Staff’s Position at this time, under the guidelines of current plans, policies and studies, is to approve the Major Site Plan because it is consistent with the current surrounding land uses and future land use recommendations.

8. Photographs



**HENDERSON COUNTY
MAJOR SITE PLAN REVIEW APPLICATION**

CONTACT INFORMATION

Property Owner:

Name: JSMG Investments, LLC Phone: (828) 255-8922

Complete Address: P.O. Box 18135 Asheville, NC 28814

Applicant:

Name: JSMG Investments, LLC Phone: (828) 255-8922

Complete Address: P.O. Box 18135 Asheville, NC 28814

Agent:

Name: _____ Phone: _____

Complete Address: _____

Agent Form (Circle One): Yes No

Plan Preparer:

Name: Robert M. Grasso, RLA Land Planning Collaborative Phone: (828) 242-0111

Complete Address: P.O. Box 2200 Asheville, NC 28802

GENERAL INFORMATION

Date of Application: 11/27/19

Site Plan Attached (Circle One): Yes No

PARCEL INFORMATION

PIN: 9652-40-2383

Tract Size (Acres): 5.13 Ac.

Zoning District: RC Regional Commercial

Fire District: FLETCHER FIRE

Supplemental Requirement# _____

Watershed: N/A

Permitted by Right

Floodplain: N/A

Special Use Permit _____

Location / Property to be developed: Property located to the north of Tract with the address, 6024 Asheville Hwy,
PIN: 9652-40-5099

County Use Only

Fee: \$ _____ Paid: _____ Method: _____ Received by: _____



PROJECT INFORMATION
 PROPERTY OWNER: JSMG INVESTMENTS, LLC
 P.O. BOX 18135
 ASHEVILLE, NC 28814
 PHONE: (828) 253-8922
 EMAIL: info@carolinanorway.com
 CONTACT: MARSHALL GREEN

LANDSCAPE ARCHITECT: LAND PLANNING COLLABORATIVE
 P.O. BOX 2200
 ASHEVILLE, NC 28802
 PHONE: (828) 242-0111
 EMAIL: lpc@landplancollab.com
 CONTACT: ROBERT M. GRASSO, RLA

CIVIL ENGINEER: DAVIS CIVIL SOLUTIONS, PA
 134 CHARLOTTE HIGHWAY, SUITE A
 ASHEVILLE, NC 28803
 PHONE: (828) 299-8449
 EMAIL: gary@dacivilsolutions.com
 CONTACT: GARY D. DAVIS, PE

SURVEYOR: SPENCER SURVEYING & MAPPING, PLLC
 1095 HENDERSONVILLE ROAD, SUITE 52
 ASHEVILLE, NC 28803
 PHONE: (828) 384-1480
 EMAIL: jason@spencersurveying.com
 CONTACT: JASON SPENCER, PLS

SITE INFORMATION

DEED BOOK/PAGE:	9652-40-2383 3399/690
ADDRESS:	NA
ZONING CLASSIFICATION:	NC REGIONAL COMMERCIAL
PROJECT ACRES:	5.13 AC. (223,568 SF)
PROPOSED USE:	FLEX OFFICE SPACE & WAREHOUSE
FLEX OFFICE SPACE SQUARE FOOTAGE:	18,000 SF
WAREHOUSE SQUARE FOOTAGE:	39,000 SF
NO. OF FLEX OFFICE SPACE UNITS:	12 UNITS
PERMITTED MAXIMUM BUILDING HEIGHT:	50'
PROPOSED MAXIMUM BUILDING HEIGHT:	50'
PERMITTED DENSITY (RESIDENTIAL):	16 UNITS/ACRE
BUILDING SETBACKS: FRONT:	30'
SIDE:	10'
REAR:	10'
PERMITTED MAXIMUM IMPERVIOUS AREA:	80%
PROPOSED IMPERVIOUS AREA:	58.81% (131,478 SF)
REQUIRED FLEX OFFICE SPACE PARKING SPACES:	36 SPACES (1 SPACE/500 SF)
PROPOSED FLEX OFFICE SPACE PARKING SPACES:	68 SPACES
REQUIRED WAREHOUSE PARKING SPACES:	10 SPACES (1 SPACE/4,000 SF)
PROPOSED WAREHOUSE PARKING SPACES:	26 SPACES
LENGTH OF ROADS:	1,636 LF (PRIVATELY MAINTAINED)
REQUIRED NO. OF PARKING LOT TREES:	19 TREES
PROPOSED NO. OF PARKING LOT TREES:	21 TREES
WATER:	HENDERSONVILLE WATER
SANITARY SEWER:	CANE CREEK SANITARY SEWER DISTRICT
UTILITIES:	DUKE ENERGY, UNDERGROUND POWER

- GENERAL NOTES:**
- ROADS & PARKING AREAS PRIVATELY MAINTAINED.
 - THE PROPERTY OWNER WILL MAINTAIN THE OPEN SPACE.
 - THE BUILDINGS WILL BE SPRINKLED FOR FIRE PROTECTION.
 - PROPOSED BUILDINGS & PARKING AREA DO NOT LIE WITHIN FLOOD HAZARD ZONE.
 - EXTERIOR PARKING LOT LIGHTING WILL CUT-OFF FIXTURES, COMPLYING WITH HENDERSON COUNTY LIGHTING REQUIREMENTS.
- ALL WEATHER SURFACE FIRE APPARATUS ACCESS
 - STORMWATER DETENTION/TREATMENT AREA FOR UNDERGROUND SYSTEM
 - DUMPSTER WITH OPAQUE SCREEN ENCLOSURE & GATES
 - 39,000 SF WAREHOUSE
 - LOADING DOCK
 - 6 UNIT FLEX OFFICE SPACE BUILDING (8,000 SF)
 - ONE-WAY EXIT DRIVE
 - 6 UNIT FLEX OFFICE SPACE BUILDING (8,000 SF)
 - FLOWERING TREE (TYP.)
 - SHADE TREE (TYP.)
 - NEW TURN-LANE (REMOVED MEDIAN ISLAND)
 - BUILDING SETBACK LINE
 - ONE-WAY ENTRANCE DRIVE

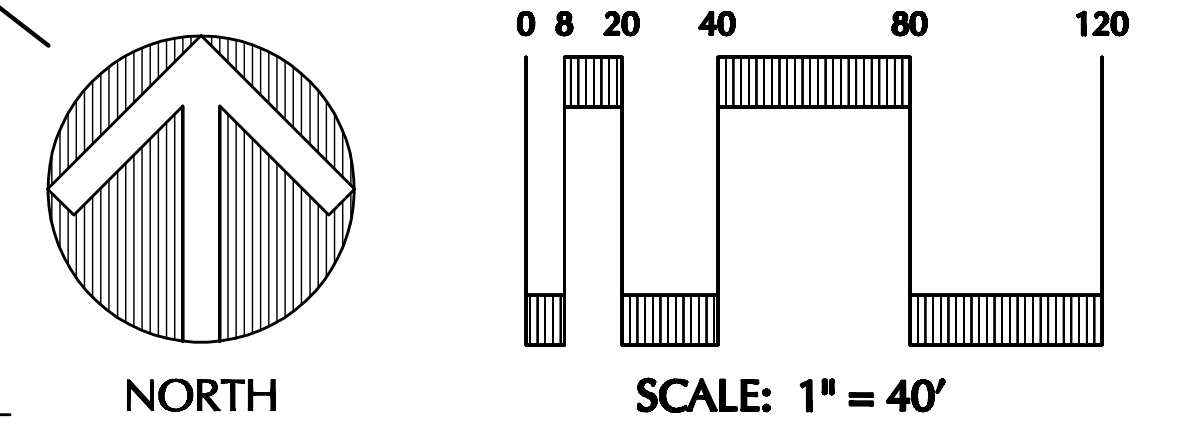
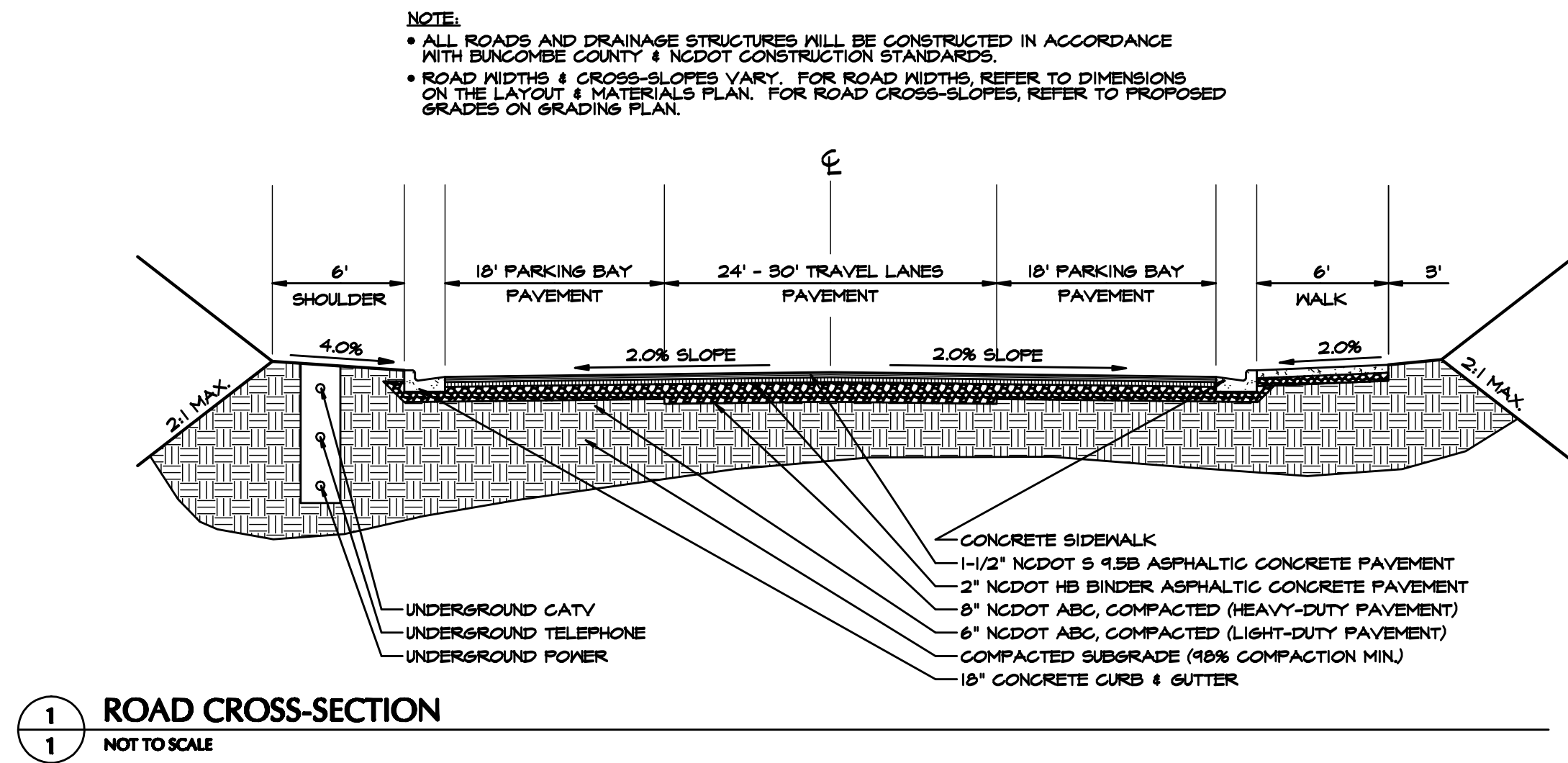
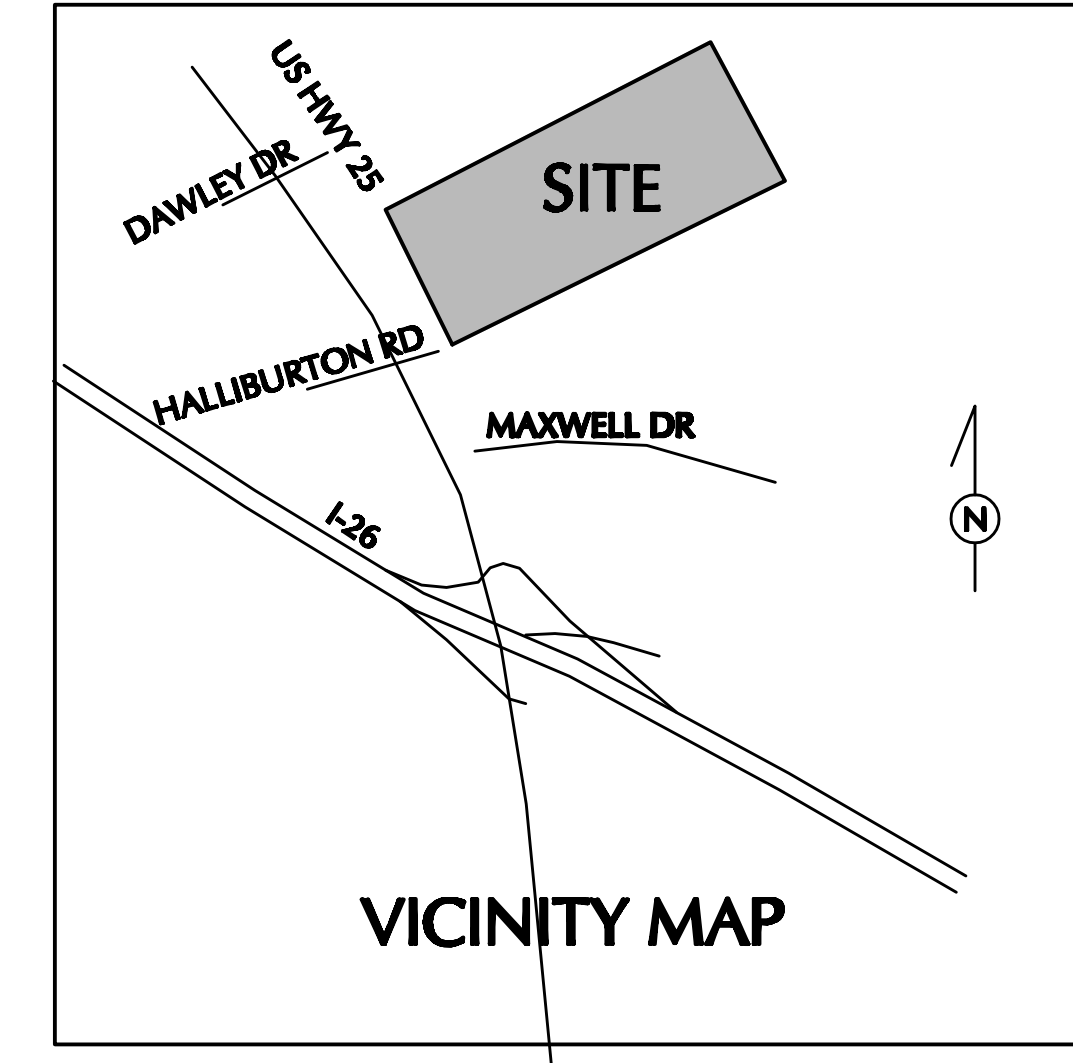

LAND PLANNING COLLABORATIVE
 Landscape Architects • Land Planners
 P.O. BOX 2200
 ASHEVILLE, NC 28802
 (828) 242-0111
 EMAIL: lpc@landplancollab.com

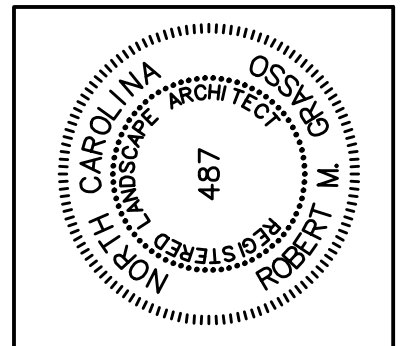

MASTER PLAN

JSMG INVESTMENTS, LLC TRACT

JOB NO.: 2019650
 DWG NAME: hwy25-site.dwg
 DATE: NOVEMBER 27, 2019

REV.	DATE	BY:
1	12/9/19	RMG
2	1/8/20	RMG
3	-	-
4	-	-
5	-	-

SHEET
 1 OF 1