

## **REQUEST FOR BOARD ACTION**

### **HENDERSON COUNTY BOARD OF COMMISSIONERS**

**MEETING DATE:** January 3, 2022

**SUBJECT:** Purchase and Installation of Cosmetology Cabinetry

**PRESENTER:** Thad Ninnemann, Project Manager HC Project Management

**ATTACHMENTS:** Yes

1. Vendor Proposal
2. N.C.G.S. 143-129 (e)(6)
3. BRCC Letter of Justification for Sole Source
4. BRCC Request for Waiver of Competition

#### **SUMMARY OF REQUEST:**

The Board is requested to approve the attached proposal and authorize staff to proceed with the procurement and installation of salon cabinetry for the BRCC Cosmetology Department as detailed in the BRCC MRTS Sink Building Cosmetology Dispensary Planned Project via the sole source exception as allowed under N.C.G.S 143-129 (e)(6). As a sole source contract with County government, approval of this agreement by the Board of Commissioners is required.

The sole proposal was received from Collins Manufacturing Company for a total price of \$33,338.03. The BRCC Cosmetology Department has had three previous renovation projects all using Collins Manufacturing Company Salon Cabinetry and would prefer to have the identical salon cabinetry provided for this phase to match the existing salon cabinetry for an esthetically pleasing environment. The salon cabinetry stations and cabinetry were custom designed and built to fit the needs of the students, the layout for the department, and to allow for a proper learning setting for the future.

The purchase and installation of the Cosmetology Salon Cabinetry is a part of the FY21/22 BRCC MRTS Planned Projects budget.

#### **BOARD ACTION REQUESTED:**

The Board is requested to accept the proposal from Collins Manufacturing Company and authorize Henderson County staff to proceed with the purchase and installation of the Cosmetology Cabinetry for the BRCC MRTS Sink Building Planned Project using the sole source exception to as allowed under N.C.G.S 143-129 (e)(6).

#### **Suggested Motion:**

*I move the Henderson County Board of Commissioners award the contract for the purchase, installation of Cosmetology Cabinetry to the sole bidder, Collins Manufacturing Company for \$33,338.03 and authorize staff to proceed with the purchase using the sole source exception to bidding as allowed under N.C.G.S 143-129 (e)(6).*



2000 Bowser Rd  
 Cookeville, TN 38506  
 Phone (800)292-6450 Fax (931) 528-5472

# Quotation

**Prepared Date** November 6, 2020  
**Quotation #** 5169-110620-01  
**Revision Date** November 17, 2021  
**Revision #** 5  
**Sales Order #**  
*Quotation valid until:* Mar 17, 2022  
*Prepared by:* Mac McAlister  
*Lead Source:* Office

**Bill To:**  
 HENDERSON COUNTY  
 ATTN: THAD NINNEMANN  
 BRCC MARSHALL MORRIS  
 110 KING STREET  
 HENDERSONVILLE, NC 28792  
 E: [MARSHALLM@BLUERIDGE.EDU](mailto:MARSHALLM@BLUERIDGE.EDU)

**Project Name:**  
 BLUERIDGE CC - DISPENSARY

**Ship To:**  
 BLUERIDGE COMMUNITY COLLEGE  
 180 W. CAMPUS DR  
 FLAT ROCK, NC 28731-4728

**Comments or special instructions:**

PRICED IN STANDARD MOSAIC LAMINATES - STAINLESS STEEL TOPS ON COLOR MIXING BAR AND INSTRUCTORS DESK SECTION

Qty	Part #	Description	Unit	Extended
1	SOCC-CLR	<b>MIXING BAR</b> - CABINETS TO BE BUILT OUT OF 3/4" INDUSTRIAL GRADE PARTICLE BOARD & COVERED IN HORIZONTAL GRADE LAMINATE WITH WATER BASED EPA APPROVED ADHESIVE. ALL JOINTS TO BE GLUED WITH SCREWS OR DOWELS. DRAWER SLIDES TO BE SIDE-MOUNTED, FULL EXTENSION, METAL SLIDES WITH ANACHROME FINISH AND 75 LBS LOAD CAPACITY. UPPER & LOWER DOOR HINGES TO BE NICKLE PLATED, 110 DEGREE OPENING WITH INTEGRATED SILENT SYSTEM. BOTTOM SECTION 80"W X 20-3/16"D WITH 3 DRAWERS, 3 STORAGE DOORS & 2 PLUMBING ACCESS DOORS. UPPER SECTION 80"W X 10"D WITH 5 STORAGE DOORS & ADJUSTABLE SHELF. COUNTER TOP & BACK SPLASH TO BE 16 GAUGE STAINLESS STEEL, #3 BRUSHED FINISH W/ STAINLESS STEEL BAR SINK & FIXTURE	\$ 5,307.00	\$ 5,307.00
1	SOCC-DSK	<b>TEACHER DESK</b> - BUILT WITH THE SAME MATERIALS AS ABOVE CABINET. DESK 105-1/4"W X 25-1/4"D X 30"H WITH STAINLESS STEEL COUNTER TOP, FOUR DRAWERS, TWO FILE CABINET SIZE DRAWERS & TWO STORAGE DOORS. ALL WITH LOCKS KEYED THE SAME. TWO 30"W SECTIONS FOR CHAIR. UPPER STORAGE CABINET AT 32"W X 10"D X 30"H WITH 2 DOORS & ADJUSTABLE SHELF. FOUR WIRE GROMMETS IN COUNTER TOP	\$ 5,543.00	\$ 5,543.00
1	SOCC-ST1	<b>STORAGE AREA 1</b> - CABINET BUILT WITH THE SAME MATERIALS AS PREVIOUS CABINETS. LEFT CABINET TO BE 54"W X 15"D X 80-3/4"H WITH 6 LOCKER SECTIONS. RIGHT CABINET TO BE 90"W X 15"D X 80-3/4"H WITH 10 LOCKER SECTIONS. EACH LOCKER SECTION TO HAVE 2 ADJUSTABLE SHELVES. CORNER LAMINATED FILLER PANEL FOR UNUSED CORNER SPACE.	\$ 7,070.00	\$ 7,070.00
1	SOCC-ST2	<b>STORAGE AREA 2</b> - CABINET BUILT WITH THE SAME MATERIALS, LOCKER SIZES AND ADJUSTABLE SHELVES AS STORAGE AREA 1 EXCEPT TO BE 114"W X 15"D X 80-3/4"H	\$ 5,900.00	\$ 5,900.00

**Note:**

- Please reference **quotation number** and **revision number** listed in top right hand corner when ordering.
- Quotation is based on the use of laminates from Collins standard laminate selections unless noted otherwise.
- 50% deposit required to place order and balance due prior to shipping.

<b>Sub-Total</b>	\$ 23,820.00
<b>Collins Installation</b>	\$ 5,624.00
<b>LTL shipment with lift gate and scheduled delivery</b>	\$ 1,786.00
<b>Approximate Sales Tax</b>	\$ 2,108.03
<b>Grand Total</b>	\$ 33,338.03

**Approximate Lead Time To Ship After Receipt of Order (ARO)** 12-13 WEEKS

If you have any questions concerning this quotation, contact:

**Mac McAlister**  
 Mobile: (919) 771-4104  
 Email: [mac@collinsmfgco.com](mailto:mac@collinsmfgco.com)

**THANK YOU FOR YOUR BUSINESS**

**Customer Signature:** \_\_\_\_\_

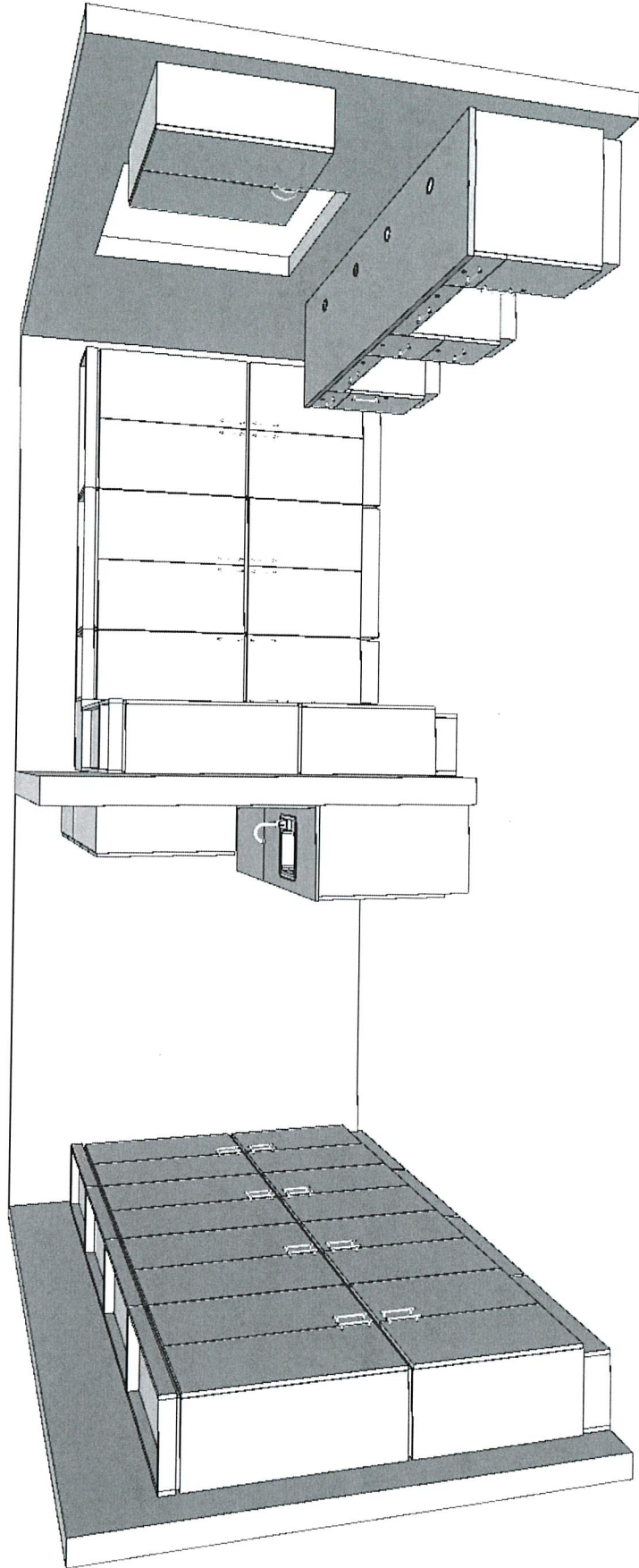

**collins**

**BLUE RIDGE COMMUNITY COLLEGE**

Darlene Cope  
180 West Campus Drive  
Flat Rock, NC 28731

CONCEPT BY: MAC MCALISTER

MSRP: \$9,950

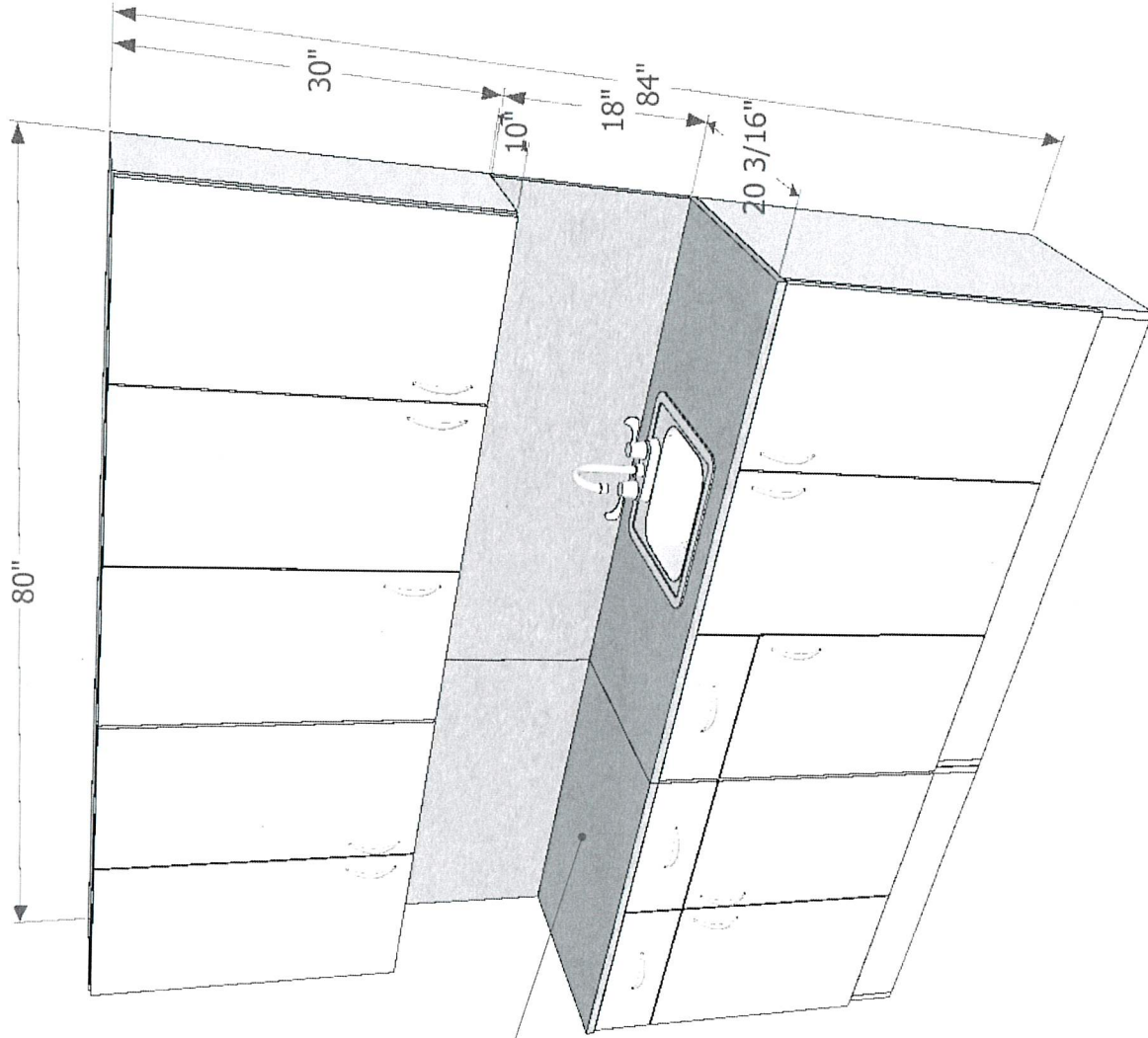

**collins**

\*CONCEPTUAL DESIGNS ONLY\*

5169-110620-01

MIXING BAR

01



MSRP: \$10,393

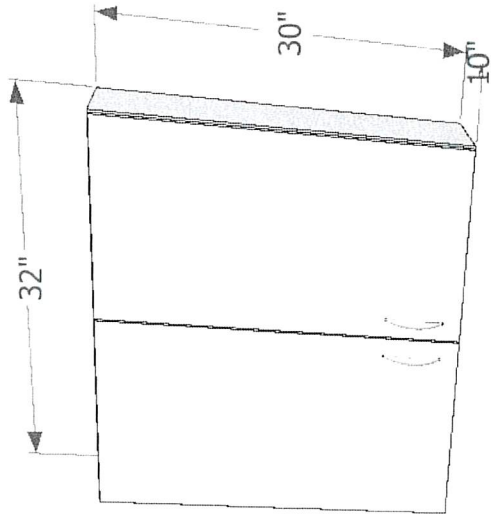

Stainless Steel countertop

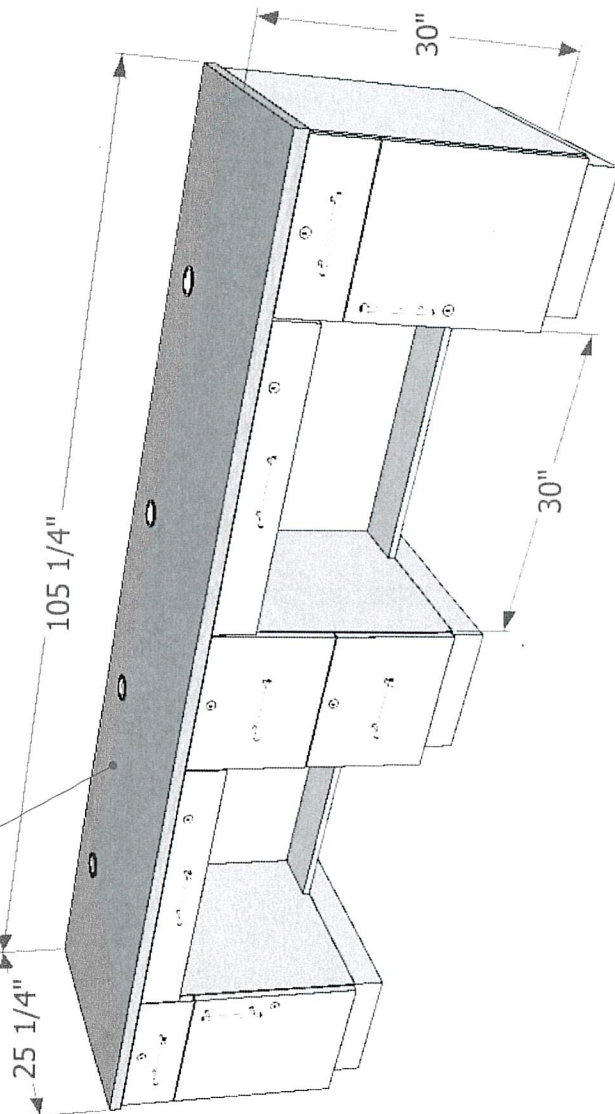

**collins**

\*CONCEPTUAL DESIGNS ONLY\*

5169-110620-01

| TEACHERS DESK

02

MSRP: \$13,241

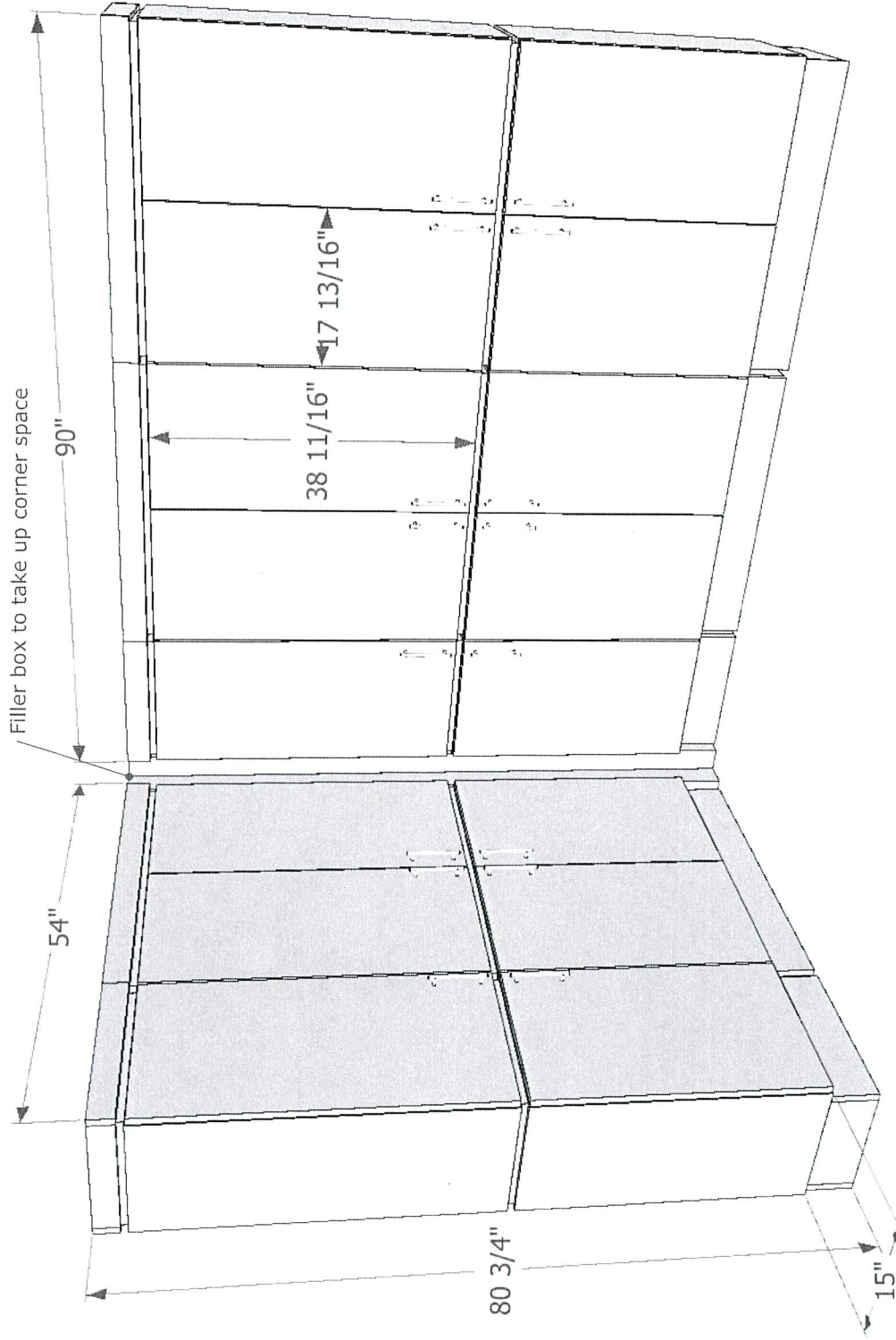

\*CONCEPTUAL DESIGNS ONLY\*

5169-110620-01

| STORAGE AREA-1

MSRP: \$11,049

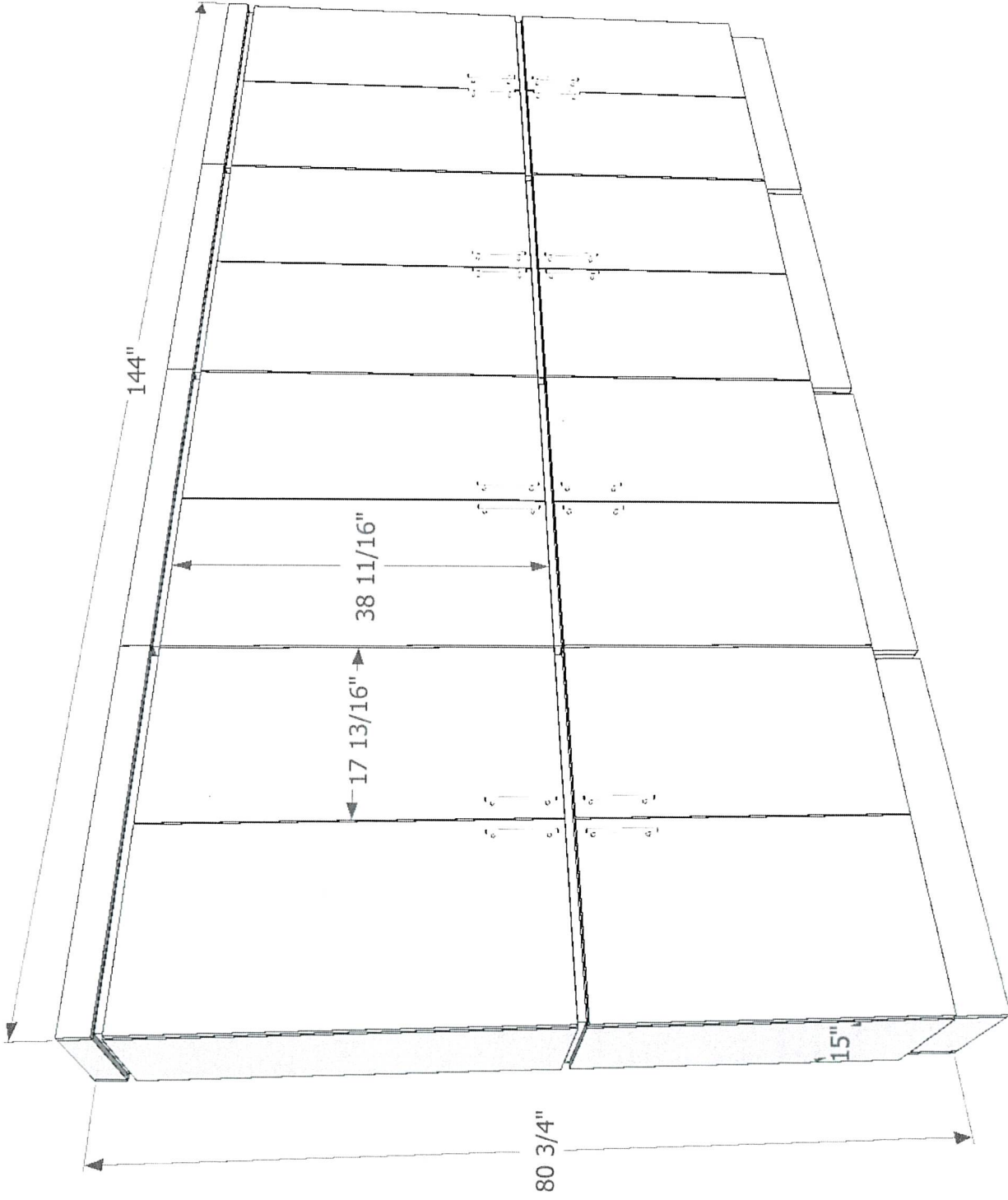

\*CONCEPTUAL DESIGNS ONLY\*

5169-110620-01

STORAGE AREA-2

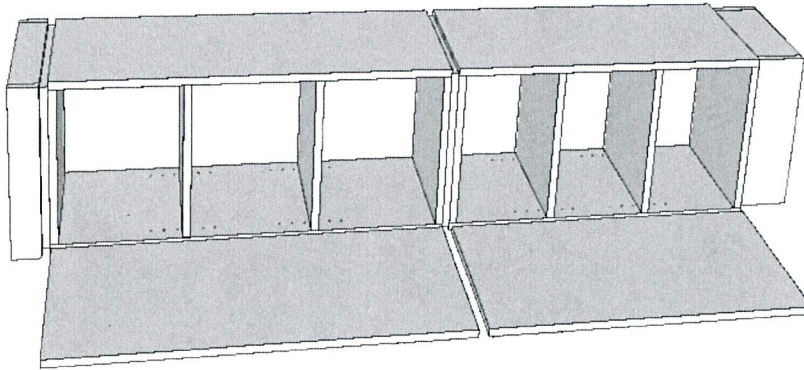
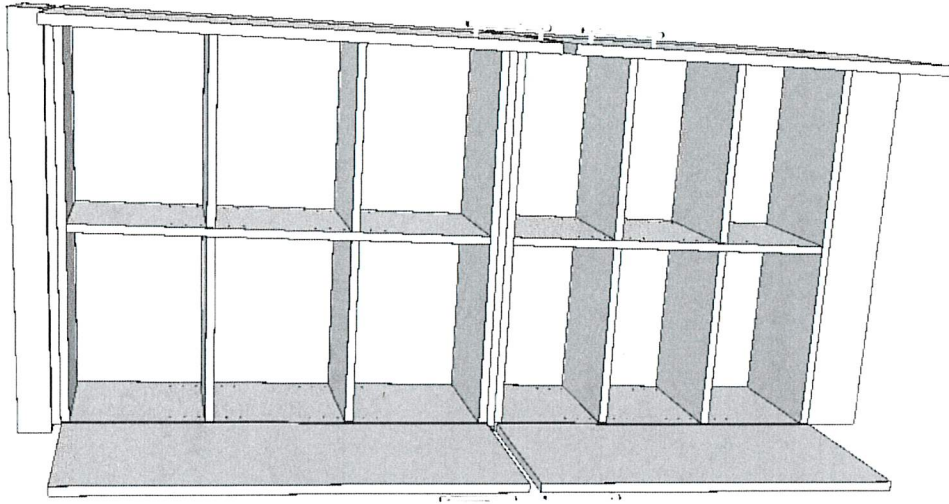



§ 143-129. Procedure for letting of public contracts.

(e) Exceptions. - The requirements of this Article do not apply to:

(6) Purchases of apparatus, supplies, materials, or equipment when: (i) performance or price competition for a product are not available; (ii) a needed product is available from only one source of supply; or (iii) standardization or compatibility is the overriding consideration. Notwithstanding any other provision of this section, the governing board of a political subdivision of the State shall approve the purchases listed in the preceding sentence prior to the award of the contract.

November 19<sup>th</sup>, 2021

## Letter of Justification

### for Storage Cabinets and Furniture in Cosmetology Dispensary

The Mixing Bar, Teacher Desk and Storage Cabinets that are to be ordered need to come from the same manufacturer as the previous salon stations that have been ordered for Phase 1, Phase 2 and Phase 3. They need to match the previous orders to create an esthetically appealing environment. The stations were custom designed and built to fit the needs of the students, and the layout of the department, to allow for a proper learning environment for the students.

These stations have a much higher quality and are designed to last for many years to come. It is a good investment in the Cosmetology department to help the program move forward and grow.

Phase 1



Phase 2



Phase 3

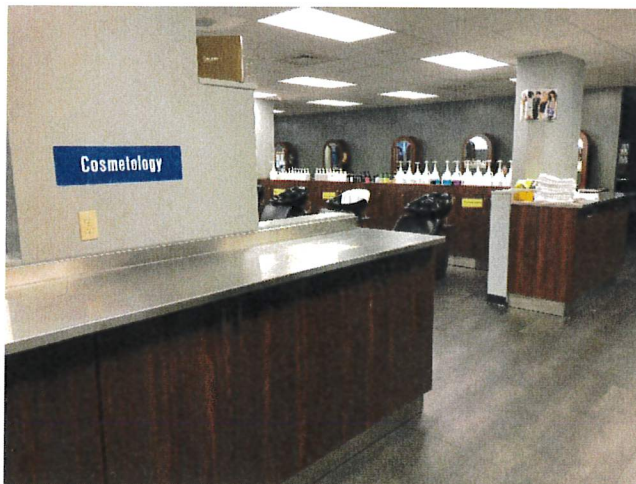

Proposed Phase 4

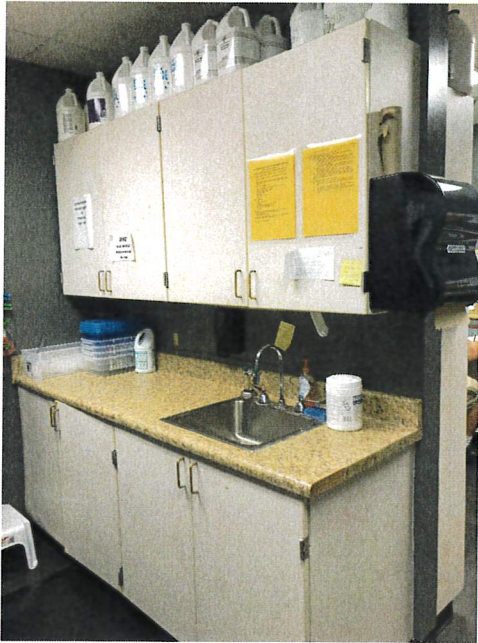

Thank you,

Darlene Cope

A handwritten signature in cursive script that reads "Darlene Cope".

Cosmetology Director/Lead Instructor  
Blue Ridge Community College





November 19, 2021

Henderson County  
Attn: Thad Ninnemann  
Capital Projects Project Manager  
100 King Street  
Hendersonville, NC 28792

To whom it may concern:

Blue Ridge Community College is requesting a waiver of competition as allowed by 01 NCAC 05B .1401. We would like to request a Waiver of Competition where standardization of compatibility is the overriding consideration. The Mixing Bar cabinets, Teachers Desk, Storage Area 1 and Storage Area 2 cabinets need to be custom constructed by the same manufacturer, Collins, to be compatible with our existing stations.

This purchase for the Cosmetology Dispensing area is for the final phase of remodeling the Cosmetology. There have been 3 previous phases of remodeling in Cosmetology. These were in 2014, 2015, 2017. All 3 previous phases exclusively used salon stations, cabinets and furniture custom built by Collins. All 3 of the previous purchases were Requests for Quotes - Waiver of Competition and were approved by the NC State Purchase and Procurement.

The style and the finish need to match exactly the existing stations. The existing stations were custom built for our Cosmetology salon by Collins. Collins is one of the leading manufacturers of salon equipment and specializes in this.

A letter from Ms. Darlene Cope, Director/lead Instructor for Cosmetology is included in our procurement package for this purchase. Ms. Cope's letter discusses the need for this equipment in her lab.

Thank you,

Marshall Morris

Project Coordinator  
Blue Ridge Community College  
(828) 329-6148

**Henderson County Campus**

180 West Campus Drive  
Flat Rock, NC 28731  
828.694.1700

**Transylvania County Campus**

45 Oak Park Drive  
Brevard, NC 28712  
828.883.2520

**Health Sciences Center**

805 6th Avenue West  
Hendersonville, NC 28739  
828.694.1700