

REQUEST FOR BOARD ACTION

Henderson County Technical Review Committee

Meeting Date: September 7, 2010

Subject: Land Development Code 2010 Annual Text Amendments (TX-2010-02)

Staff Contact: Autumn Radcliff, Senior Planner

Attachments:

1. Staff Memorandum
2. Draft Article III, Subdivision Regulations (substantive modifications highlighted in red)
3. Non-subdivision Related Text Amendments

SUMMARY OF REQUEST:

The Henderson County Land Development Code (LDC) was adopted with the anticipation that it would be reviewed each year and amended as needed. The 2010 LDC amendments (TX-2010-02) are based on concerns from both staff and County boards and committees (See Attachment 1 and 3). The proposed amendments cover various topics but primarily involve reorganizing the subdivision regulations and addressing some the Planning Boards concerns with special subdivisions (See Attachment 2).

Before adopting the proposed text amendments to the LDC, the Board of Commissioners must hold a public hearing. The Planning Board and the Technical Review Committee (TRC) must review and provide a recommendation on these proposed amendments. Staff will provide an overview of the proposed text amendments at the TRC meeting.

Suggested Motion:

I move the Technical Review Committee recommend the Board of Commissioners approve the proposed Land Development Code 2010 Annual Text Amendments (TX-2010-02), as discussed.

HENDERSON COUNTY
Planning Department

213 First Avenue East • Hendersonville, NC 28792
Phone 828-697-4819 • Fax 828-697-4533

MEMORANDUM

TO: Planning Board

FROM: Autumn Radcliff, Senior Planner

DATE: August 26, 2010

**SUBJECT: Land Development Code 2010 Annual Text Amendments (TX-2010-01):
Amendments to the Subdivision Regulations**

The Henderson County Land Development Code (LDC) was adopted with the anticipation that it would be reviewed each year and amended as needed. The 2010 LDC amendments (TX-2010-02) cover various topics but primarily involve reorganizing the subdivision regulations and addressing Planning Boards concerns, corrections and clarifications to existing text. The subdivision ordinance was initially inserted into the LDC at the time of its adoption with minimal changes. Staff has reorganized and formatted the subdivision regulations to be user friendly and to address Planning Board concerns. **The only substantive modifications to the existing subdivision regulations and standards are highlighted in red (See Attachment 2).** Text that is not highlighted in red reflects the existing unchanged standards. Below is a description of all proposed changes to the existing subdivision regulations and standards.

Changes to Existing Subdivision Regulations and Standards:

- (1) **Subdivision Amendment 1: Existing Cemeteries in a Subdivision.** The Henderson County Cemetery Advisory Committee requested new subdivisions require existing cemeteries be deeded as a separate lot with road access. Cemetery lots are non-standard and will not count toward overall density calculation.

The proposed amendment requires existing cemeteries be deeded as a separate lot with a 20 foot wide right-of-way (ROW) and a 12 foot wide travelway.

- (2) **Subdivision Amendment 2: Land Disturbing Activity.** The Planning Board was concerned that no provisions were provided to address illegal land disturbing activity in conjunction with a subdivision.

A provision would be added that unapproved land disturbing activity in conjunction with a subdivision is a violation of the LDC and may be subject to County penalties as described in Article XII of the LDC.

- (3) **Subdivision Amendment 3: Expansion of a Subdivision.** The Planning Board was concerned that due to the 3 year expansion hold, minor subdivisions that expanded before this time limitation would have to reapply as a major subdivision regardless of the number of lots created. The Planning Board was also concerned that the after the allotted time, an expansion could occur without any improvements to the existing private roads; allowing applicants to serve lots on roads that would not meet the minimum subdivision road standards. The Planning Board recommended

removing these time limitations so applicants would be aware and required to upgrade existing private roads (within the subdivision) to meet County regulations.

The proposed regulations would allow previously approved subdivisions to be expanded without reapplying as a major subdivision provided that certain criteria have been met (removes time limitations that would exempt previously approved subdivisions).

- (4) **Subdivision Amendment 4: Road Certification.** The County has inspected roads which appeared to not meet subdivision regulations. The burden of proof is always the responsibility of the applicant. The proposed regulations add a provision that the Subdivision Administrator may require engineering certification that the new road meets the LDC requirements and further may request a core sample in certain circumstances were no engineering certification exists.
- (5) **Subdivision Amendment 5: Road Standards.** The Planning Board and staff expressed concerns that the existing road standards (based on the number of lots served) did not correspond with the number of lots served by subdivision types. For example, a special subdivision (5 or fewer lots) would have to meet the standards for limited local roads if serving only 4 or fewer lots, and the standards for local roads if proposing 5 lots. In addition, the Board stated concerns that special subdivision had no other alternatives to constructing a new road. To address these concerns, staff recommends correcting the number of lots served by limited local and local roads, and adding a provision for using private driveway easements and alleys.
 - a. **Alleys.** The use of alleys allows flexibility in subdivision design but would require some minimum standards. Staff recommends adding a provision that alleys may be used to access lots within a subdivision provided that those lots have frontage on a private or public road that is accessible. The alleys would be required to have a minimum 20 foot wide right-of-way and 12 foot wide travelway that could be paved or graveled.
 - b. **Private Driveway Easements.** The existing conservation subdivision standards allow for the use of private driveway easements serving up to 2 lots. This amendment would increase the number of lots served by a private driveway easement to 3 lots and would allow all subdivisions (including special subdivisions) to propose private driveway easements (existing standards for private driveway easements would apply).
 - c. **Private Subdivision Limited Local Roads.**
 - i. **Number of lots served.** To address the issue with the number of lots served verses the type of subdivision, the private subdivision limited local roads will be amended to serve up to 5 lots instead of 4 lots (will match the special subdivision standards).
 - ii. **Right-of-Way restrictions.** The Planning Board had discussed adding a provision that would require the dedication of a 45 foot right-of-way (in lieu of a 30 foot right-of-way) to accommodate required road improvements for future subdivision expansion in situations where the maximum density could achieve more than 5 lots. This provision would allow for a special subdivision to be expanded in the future without having to acquire additional right-of-way.
 - d. **Private Subdivision Local Roads.** To address the issue with the number of lots served verses the type of subdivision, the private subdivision local roads will be amended to serve up to 6 lots instead of 5 lots (will match the special subdivision standards and the amendments to the limited local roads).

(6) Subdivision Amendment 6: Special Subdivision Standards.

- a. Use of existing roads. The Planning Board discussed allowing credit for existing roads that had a travelway width of less than 12 feet. This could eliminate unnecessary grading to widen a road by only 1 or 2 feet, especially if topographical limitations existed, and lessen the burden for small subdivisions of land for homes that may already be served by an existing road. This amendment would allow, upon inspection and approval by the Planning Director, an existing road of no less than 9 feet to be used to access a special subdivision. Some improvements such as 4-inches of gravel may be required and dedication of right-of-way per the subdivision road standards would apply. Existing roads would need to adequate shoulder and vertical clearance to be accessed by emergency vehicles.
- b. Certificate of Understanding. The Planning Board requested that the requirement for the Certificate of Understanding be made as part of the subdivision application. Currently the certificate of understanding is required on the final plat for special subdivisions. This amendment would require the certificate of understanding for all subdivisions types (as part of the application) and eliminate it from the final plat requirements.

- (7) **Subdivision Amendment 7: Conditional Letter of Approval.** The conditional letter of approval is issued by the Subdivision Administrator for a minor subdivision and allows the applicant to begin construction. This amendment would add a provision that the conditional letter of approval is valid for a period of 3-years from the issuance date unless the subdivision approval is expanded. Note: This amendment is found in the Article XI (Review Processes and Procedures).

Amendments to the Improvement Guarantee Standards:

The proposed subdivision amendments made substantial modifications to the improvement guarantee section and existing standards (this section is a subpart of the subdivision regulations). These changes (highlighted in red on attachment 2) will provide the County a better mechanism for covering costs associated with completing required improvements (includes associated costs with administration, construction and project management) if the applicant is unable to complete the project. Below is a description of the substantive modifications to the improvement guarantee standards.

- (1) **Application Requirements.** The proposed changes require that before an applicant can apply for an improvement guarantee the following apply:
 - a. A minimum of 50 percent of the required improvements (based on total project cost that the applicant is guaranteeing) is in place (includes rough grading of proposed roads subject to the improvement guarantee).
 - b. All local, state and federal permits for the development must be approved and copy of said approval provided to the Subdivision Administrator (includes Army Core permits, stream and wetland mitigation fees/permits, water and sewer permits, etc.).
 - c. All associated design plans and construction specifications for the required improvements (i.e. roads, bridges, water and sewer infrastructure, stormwater infrastructure, pedestrian infrastructure, etc.) are submitted to the Subdivision Administrator.
- (2) **Cost Estimate Standards.** Add a provision requiring the applicant to include the following:
 - a. Separate estimates for roads, bridges, water and sewer infrastructure, stormwater infrastructure, pedestrian infrastructure, etc. consistent with submitted design plans construction specifications.

- b. All associated fees for remediation work required for the proposed improvements (unless proof of payment for remediation fees is provided to the Subdivision Administrator).

- (3) **Improvement Guarantee Instrument.** Amend the existing standards requiring the applicant to guarantee in the amount of 150 percent, instead of 125 percent, of the cost to complete the work as determined by cost estimate amounts. This provision would also apply to extensions. The additional 50 percent covers inflation and additional costs (costs associated with violations, sedimentation and erosion control, administrative and project management) that may be required to complete the project.

Existing standards allow for portions of the guarantee to be released as work progresses. This provision would also require the applicant to provide a new cost estimate detailing the work that has been completed and that is remaining when requesting a release.

- (4) **Terms of the Improvement Guarantee.** Add a provision requiring the following terms be expressly stated in the performance agreement and that the lending institution be a from a national association or FDIC registered group. The following terms shall be stated in the performance agreement:
 - a. The applicant shall be provided 15 days to identify a new security provider or prove alternate security where the security provider is in default, bankruptcy, or otherwise determined to be insolvent by the County after which time the County may call the improvement guarantee.
 - b. The applicant shall provide the County with specific benchmarks for completion of work and, as a term of the agreement, should the applicant fail to meet the self-imposed benchmarks the County may call the improvement guarantee.
 - c. If in violation of any other provision of this Chapter 200A, Henderson County Land Development Code, where the applicant has been notified of the violation, and the applicant has been provided the period for remediation authorized by the approving agency, and where applicant is in continued violation, the County may consider this to be a breach of the agreement and call the improvement guarantee to prevent further violation of Chapter 200A, Land Development Code.

Violations and Penalties. Add a provision that if an applicant of a subdivision is in violation of any County regulations (including Soil Sedimentation and Erosion Control Permits) the County will not release the improvement guarantee prior to the expiration date unless the violations are corrected.

This provision would also add language allowing the County the ability to charge costs associated with construction and project administration for any executed improvement guarantee. The County may currently do this but the proposed change will state this as part of our regulations.

ARTICLE III
SUBDIVISION REGULATIONS

Subpart A. General Subdivision Regulations

§200A-74. Purpose

The purpose of this Article is to promote, through proper planning, health, safety and general welfare by providing for the orderly *subdivision* of land in Henderson County. This Article is deemed necessary to:

- A. Establish procedures and standards for the *subdivision* of land;
- B. Provide for orderly growth and development;
- C. Protect and enhance property ownership and land values;
- D. Provide for dedication or reservation of *road right-of-way*;
- E. Assure the proper design and installation of *roads* and utilities;
- F. Assure proper legal description, identification and recordation of property boundaries to maintain an accurate, up-to-date land records management system;
- G. Promote environmental quality;
- H. Preserve areas of the County with productive soils for continued agricultural and *forestry use* by preserving blocks of land large enough to allow for efficient operation;
- I. Encourage the maintenance and enhancement of habitat for various forms of wildlife and to create new woodlands through natural succession and reforestation where appropriate;
- J. Minimize site disturbance and *erosion* through retention of existing vegetation and avoiding development on *steep slopes*; and
- K. Preserve open land, including those lands that contain *unique* (and sensitive) *natural areas*.

§200A-75. Comprehensive Plan

This Article is based on *Comprehensive Plan* goals and objectives. All land may not be suitable to be subdivided for the purpose of dense development due to:

- A. Severe topographic conditions;
- B. Inadequate *road* access;
- C. Distance from services;
- D. *Unique natural areas*;
- E. Soils that do not easily support soil drainage systems; and/or
- F. The proximity to existing and incompatible land *uses/zoning*

The reviewing agency should consider *Comprehensive Plan* goals and objectives when reviewing *subdivisions*.

§200A-76. Approval for Subdivision Plats

A *final plat* must be prepared and approved when a *subdivision* of land occurs (See §200A-311). *Final plats* must be recorded within 18 months of approval or they become null and void and must be re-approved by the appropriate authority.

§200A-77. Land Disturbing and Construction Activity

No land disturbing or construction activity carried out in conjunction with the development of a *subdivision* shall begin until a development plan has been approved. **This shall be deemed a violation of the subdivision regulations of this Chapter (See §200A-345-Violations)**

§200A-78. Subdivision Types

Subdivisions shall be either: special, *minor*, *nonstandard* or *major*. Each type of *subdivision* includes subtypes:

- A. Nonstandard Subdivision Subtypes. Public utility (pump station, water tank, etc.), *special use lot* (*sign lot*, *common area*, etc.) or *cemetery lot* (specifically excluding residential, commercial, office institutional, industrial or mixed-use).
- B. Special Subdivision Subtypes. Residential.
- C. Minor Subdivision Subtypes. Residential.
- D. Major Subdivision Subtypes. Residential, commercial, office institutional, industrial or mixed-use.

Subpart B. Regulations Applicable to All Subdivision Types and Subtypes

§200A-79. Road Frontage and Existing Off-Site Access.

Tracts to be *subdivided* must have a minimum of: (1) 30 feet of frontage on an existing public road, or (2) private *rights-of-way* no less than 30 feet in width to a public road. *Applicants* shall have the burden to prove private *right-of-way* and existing off-site access is legal, permissible and permanent (evidence may include property deed, title search, recorded *plat*, or other documentation provided by the *applicant*).

Where the minimum frontage and off-site access requirements cannot be met the maximum number of *lots* into which a *tract* may be divided shall be no more than one (1) lot per acre.

Where the minimum road frontage and existing off-site access requirements can be met but the grade of the *road* at any point in the existing off-site access exceeds 18 percent (paved) or 15 percent (gravel), and the *applicant* is proposing more than five (5) *lots*, the approving agency will review the application on a case-by-case basis.

§200A-80. Lot Designs.

New subdivision *lots* shall:

- A. Abut on an approved *road* or driveway easement (See Article III, Subpart C. Subdivision Road Standards Applicable to All Subdivision Types and Subtypes);
- B. Be no narrower than 30 feet in width where abutting the *right-of-way* or for purposes of the driveway easement;
- C. Be calculated excluding *road right-of-way* to determine size;
- D. Be of a size, width, depth, shape and orientation reasonable for the type of development;
- E. Where possible, have side *lot* lines at right angles or radial to the *roads* faced; and
- F. Not be designed as *flag lots* except where approval may be obtained from the reviewing agency for unusual circumstances (including severe topographic conditions, the presence of *unique natural areas*, preservation of working agricultural lands, or other limiting site conditions).

§200A-81. Certificate of Understanding.

The certificate shall:

- A. Be signed by the property owner(s) and provided at the time of subdivision application submittal;
- B. Acknowledge that all *lots* created from a parent tract will count toward the total number of *lots* permitted under density regulations.
- C. Acknowledge that upgrading existing improvements (including roads) may be necessary in order to expand.

§200A-82. Subdivision Names and Name Signs.

The name of a *subdivision* shall not be substantially identical or similar as to likely cause confusion among prospective purchasers to any other *subdivision* or named community in the County. A community identification/subdivision sign: (1) may be provided at the primary entrance, (2) shall be in conformance with the *sign* regulations of Article VII, and (3) should be located in dedicated *sign easements*.

§200A-83. Cemeteries.

Existing cemeteries shall be deeded as a separate lot in the subdivision and shall be accessed with a minimum twenty (20) *foot wide right-of-way* and a twelve (12) foot wide paved or graveled *travelway*.

§200A-84. Advisory Provisions.

- A. Soils Map. *Applicants* for *subdivisions* with *lots* smaller than one (1) acre in size should consult a soils map of the property and be knowledgeable of the suitability of ground absorption systems on the property.
- B. Utility Easements. Utility *easements* should be:
 - (1) Centered on rear or side *lot* lines,
 - (2) At least 20 feet in total width, and

(3) Identified following discussion with the appropriate utility agency.

C. *Stream Setbacks*. See §200A-219 (*Perennial and Intermittent Surface Water Buffers*).

D. *Traffic Impact Study (TIS) and Emergency Services Impact Report (ESIR)*. See Article IV for traffic impact study and emergency services impact report requirements.

§200A-85. Conservation Subdivision Standards.

A. *Open space* shall:

- (1) Comprise a minimum of 25 percent of the project area.
- (2) Be composed of (in order of which lands should be designated as open space first): *primary conservation area*, *secondary conservation area*, and any remaining lands necessary.
- (3) Be designated so that a minimum of 50 percent of the proposed open space is contiguous and, where possible, adjoins *open space* or other *protected areas* (including protected forests or wildlife areas) outside the project area.
- (4) Be designated so that, where possible, a majority of the lots directly abut *open space* to provide residents with direct views and access.
- (5) Be accessible by safe and convenient pedestrian access from all adjoining *lots* (except in the case of farmland or other resources areas vulnerable to trampling damage or human disturbance).
- (6) Be used as follows:
 - a. Conservation of natural resources, archeological resources or historical resources;
 - b. *Agriculture*, horticulture, or silviculture, provided all applicable *best management practices* are used to minimize environmental impacts;
 - c. Passive recreation;
 - d. Active recreation provided *impervious surfaces* are limited to a maximum of 12 percent of the total *open space* area;
 - e. Nonstructural stormwater management practices;
 - f. *Easements* for drainage, access, and underground utility lines; and
 - g. Water, septic, and sewer systems.
- (7) Not be used as follows:
 - a. For motor vehicles (except for maintenance purposes as provided for in the *Open Space Management Plan*); and
 - b. Roads, parking lots and impervious surfaces (except when accessory to active recreational uses).

B. *Open Space Ownership*. The *applicant* must identify current and future owner(s) of *open space* responsible for maintaining the area/facilities. The responsibility for maintaining

the *open space* and its facilities shall be borne by the owner. If a homeowners' association is the owner:

- a. Membership in the association shall be mandatory and automatic for all homeowners in the *subdivision* and their successors; and
 - b. The association shall have lien authority to ensure the collection of dues from all members.
- C. Open Space Management. The *applicant* shall submit "Open Space Management Plan" which includes:
- (1) A statement allocating maintenance responsibilities and establishing guidelines for the upkeep of *open space* and its facilities;
 - (2) Cost estimates for maintenance, operation and insurance needs for the *open space*;
 - (3) A means by which funds will be obtained for all management expenses;
 - (4) A provision allowing the *Subdivision Administrator* to approve plan change; and
 - (5) Criteria for plan enforcement.
- D. Legal Instrument for Permanent Protection. *Open space* shall be protected in perpetuity by a binding legal document recorded with the deed. The document shall be one of the following:
- (1) Permanent conservation *easement* in favor of either:
 - a. A land trust or similar conservation-oriented non-profit organization with legal authority to accept such *easements*. The organization shall be bona fide and in perpetual existence and the conveyance instruments shall contain an appropriate provision for retransfer in the event the organization becomes unable to carry out its functions; or
 - b. A governmental entity with an interest in pursuing goals consistent with the intentions of this Section.
 - (2) Permanent restrictive covenant for conservation purposes.
 - (3) Equivalent legal tool providing permanent protection, subject to approval by the County Attorney.
- The instrument shall include all restrictions contained in this section (§200A-85, Conservation Subdivision Standards), and any further restrictions the *applicant* chooses to place on the *use* of the *open space*.
- E. Open Space Density Bonus. Base density is determined by the zoning district in which the *subdivision* is located. Conservation subdivisions proposing more than the minimum required *open space* may be eligible for increased densities. Table 3.1 outlines the criteria for density bonuses. Lands under conservation easement shall not be counted when determining density bonuses. Permitted housing densities shall not exceed the maximum allowances of any applicable *water supply watershed* requirements.

Table 3.1. Open Space Density Bonuses				
Percent <i>Open Space</i> (%)	25-30	31-40	41-50	>51
Percent Housing Density Increase (%)	N/A	10	15	20

- F. Agricultural Preservation Density Bonus. Base density is determined by the zoning district in which the *subdivision* is located. Conservation subdivisions proposed for sustaining existing on-site bona fide agricultural operations are entitled to a five (5) percent increase in permitted density. Residential *lots* in these *subdivisions* should be located in areas less suitable for agricultural production with prime farmland being reserved as *open space*. *Lots* should be located where agricultural operations do not interfere with the safety and well being of future residents. The reviewing agency may require vegetative buffering and/or additional *setbacks* between agricultural operations and *lots* to mitigate potential impacts of noise, vibration, light, and/or odor. This five (5) percent bonus may be used in conjunction and in addition to any applicable *open space* density bonus. Permitted housing densities shall not exceed the maximum allowances of any applicable *water supply watershed* requirements.
- G. Structure Placement. Structures should be placed as closely to *internal roads* as permitted. The reviewing agency may reduce the front yard setback to a minimum of five (5) feet; taking into consideration sound engineering, public safety concerns and community character when applying the standards. *Structures* may be: (1) located in the *side yard* setback required by the zoning district regulations; and (2) placed as closely together as permitted by the North Carolina State Building Code.
- H. Exemption. Conservation subdivision standards can be applied to any subdivision type, but are not required by this Chapter.

Subpart C. Subdivision Road Standards Applicable to All Subdivision Types and Subtypes

§200A-86. Road Disclosure.

North Carolina General Statute (NCGS) §136-102.6 requires a developer disclose to each buyer of property the following:

- A. The ownership (public or private) of the *road* serving the *lot*,
- B. How the *road* will be maintained, and
- C. Who shall be responsible for such maintenance.

The law further requires certain *road* maintenance agreements be executed.

§200A-87. Right-of-Way

Right-of-way standards apply within the property being developed. *Rights-of-way* shall be capable of supporting a *road* by meeting the minimum width specified by this Chapter (See Table 3.3). Any portion of an existing recorded *right-of-way* which does not meet minimum width requirements of this Chapter shall be upgraded to:

- (1) Meet the full *right-of-way* requirement when the right-of-way is surrounded by or abutting the tract; or
- (2) Provide one-half (1/2) of the required *right-of-way* (measured from the centerline of the existing *right-of-way*) when the *right-of-way* is not completely contained by the tract to be subdivided shall be upgraded to.

§200A-88. Out of County Access

Access to a proposed *subdivision* through another County shall meet or exceed all *right-of-way* and road requirements herein.

§200A-89. Existing Private Roads

Any portion of an existing private *road*: (1) located in an existing recorded private *right-of-way* and (2) surrounded by the *tract* to be subdivided shall be upgraded to meet the *road* standards of this subpart.

§200A-90. Road Construction.

Roads should be constructed (1) along the contour of the land because of the difficulty of operating *vehicles* on steep grades and high potential for *erosion*, and (2) so that water will drain from the *road* surface into side ditches.

Roads shall:

- A. Be constructed with suitable stone and compacted properly,
- B. Be constructed on a subbase of suitable soil capable of supporting it, and
- C. Not be constructed on used asphalt (an unacceptable base course).

A professional engineer or professional surveyor must certify, or provide applicable proof, that the roads were constructed to standards prescribed in this Subpart C. Subdivision Road Standards Applicable to All Subdivision Types and Subtypes and approved development plan. This may be accomplished by on-site supervision by the engineer or his designee during the construction of the *road*, or through a series of core sample tests at appropriate key areas or as requested by the *Subdivision Administrator*. The core samples should be spaced accordingly and the location and number of core samples should be agreed upon by the engineer and *Subdivision Administrator* prior to testing. *NCDOT* certification is not required.

§200A-91. Shoulder Stabilization.

Permanent stabilization of soils to prevent erosion shall be achieved by seeding areas disturbed by the construction of a *road* (including cut and fill slopes, shoulders, ditch banks, etc.) as soon as feasible after *road* construction. The *Subdivision Administrator*, where seasonal weather prevents seeding, may require:

- A. An improvement guarantee be posted with the County to ensure the installation of permanent stabilization; and
- B. Other materials (straw, mulch, etc.) be applied temporarily until seed can be sewn.

§200A-92. Road Names.

Road names are required for all public and private roads (including alleys and *driveway easements*) that access more than two (2) lots. Proposed names for *roads* shall:

- A. Be pre-approved by Henderson County in accordance with Chapter 142 of the Henderson County Code, Property Addressing.
- B. Not duplicate or be phonetically similar to existing road names, irrespective of the use of the suffix (i.e., road, avenue, boulevard, drive, place, court etc.).
- C. Not exceed 15 characters, including spaces (not including prefixes and suffixes).

A proposed *road* obviously in alignment with an existing named *road* shall bear the name of existing *road*.

§200A-93. Road Name Signs and Regulatory Signs.

Road name signs and *regulatory signs* (speed limit signs, stop signs, etc.) shall be provided in accordance with Chapter 142 of the Henderson County Code, *Property Addressing* and with applicable local, state and federal laws, rules and regulations.

§200A-94. Road Drainage and Culverts.

Road drainage structures, ditches, and culverts shall be designed and constructed in accordance with *State Road Standards* and with sufficient depth and width to carry the expected volume of *stormwater runoff*. Culverts may be required where the *road* crosses streams or minor *watercourses*. *Best Management Practices* should be utilized for road swales (turf matting and vegetation, etc.) to control *erosion* and transport of *sediment* and to filter pollutants from *stormwater runoff*.

§200A-95. Stub Roads.

Stub roads shall be designed in locations which will permit the future extension of *subdivision roads*.

§200A-96. Road Type Designation.

Applicants shall indicate if *roads* are to be public or private on applications, plans and plats. Where private *roads* are proposed as extensions of existing *public roads*, the developer must clearly justify why proposed *roads* should not be extended for public use. Private *roads* may become public if accepted into the *public road* system by *NCDOT*.

- A. *Public Roads*. Public roads (and their associated public bridges) shall:
 - (1) Be designed and constructed in accordance with *State Road Standards*.
 - (2) Be offered dedication to the public (though this does not guarantee *NCDOT* will accept or agree to assume the maintenance responsibility of the proposed *public road*).
- B. *Private Roads*. Private roads shall be the standards of §200A-98, Residential Private Road Standards by Road Classification or §200A-97 Private Road Standards for Commercial, Office Institutional, Industrial, and Mixed-Use Subdivisions.

§200A-97. Private Road Standards for Commercial, Office Institutional, Industrial, and Mixed-Use Subdivisions.

Draft Article III, Subdivision Regulations
(Substantive modifications highlighted in red)

Private roads and bridges shall be built to *State Road Standards* for commercial, office institutional, industrial or mixed-use subdivisions.

§200A-98. Residential Private Road Standards by Road Classification.

If not specified in this section (Article III, Subpart C: Subdivision Road Standards Applicable to All Subdivision Types and Subtypes) and its Table 3.3, the design and construction of private roads shall be reviewed using *NCDOT* standards and requirements which reflect local *NCDOT* District Engineer policy modifications.

Private roads shall: (1) Be designated based on the number of *lots* served (See Table 3.2); (2) be designed and constructed in accordance with the standards of this Article (see Table 3.3); and (3) be designed to provide, at all times, adequate and unobstructed access for emergency response.

Table 3.2 Subdivision Private Road Classification by Number of Residential Lots Served					
Road Classification	Subdivision Collector	Subdivision Local	Limited Local	Private Driveway Easement	Alley
Number of Residential Lots Served	50+	6 to 49	1-5	1-3	NA

Private roads shall meet the minimum design and construction standards according to the following road classifications:

- A. Private Subdivision Collector Road. A “*private subdivision collector road*” shall be required where the road serves:
- (1) 50 or more units (existing or proposed) within the proposed subdivision or as an aggregate of the proposed subdivision and any other development to which it connects,
 - (2) As a through-road connecting lots within a subdivision to more than one (1) public thoroughfare, or
 - (3) A nonresidential facility within a residential development, (i.e. clubhouse, golf course, etc.)
- B. Private Subdivision Local Road. A “*private subdivision local road*” shall be required where a *private subdivision collector road* is not required and a *private subdivision limited local road* is not permitted.
- C. Private Subdivision Limited Local Road. A “*private subdivision limited local road*” shall be permitted where the road serves:
- (1) **No more than five (5) lots or principal units.**
 - (2) Only as a maintenance and/or emergency access (regardless of the number of *lots* it adjoins provided the road shall not be used to access *lots* and appropriate signage is provided).

- D. Private Driveway Easements. A private “*driveway easement*” shall be permitted where the driveway serves no more than three (3) lots (the lots served by the easement shall be identified on all plans and plats). Final plats must contain a note conveying maintenance responsibility of the *easement* to the homeowners’ utilizing it to access their property. The note shall state *easement(s)* must be maintained to allow clear passage for emergency response vehicles.
- E. Alley. An alley shall be permitted where the residential lot is also accessible by another public or private road and the alley serves as primary access for the future homeowner and for utility services (i.e. trash collection). Visitors to the residential lot will use the principal access road to the property.

Table 3.3. Subdivision Private Road Standards						
Requirements	Private Road Classification					
	Subdivision Collector	Subdivision Local	Limited Local	Private Driveway Easement	Alley	
Number of Residential Lots Served	50+	6 to 49	1-5 ²	1-3	-	
Right-of-Way Width (ft.)	Roads (feet)	50	45	45	-	20
	Cul-de-sac (radius)	-	50	50	-	-
Easement Width (ft.)	-	-	-	30	-	
Sight Distance on Vertical Curves (ft.)	150	110	110	-	-	
Maximum Center Line Length (ft.)	N/A	N/A	N/A	500	-	
Center Line Curve Radius (ft.)	110	90	90	-	-	
Maximum Grade %	Stone Only	12	15	15	-	-
	Paved Surface	16	18	18	-	-
Minimum Travelway Width (ft.) (two-way road)	18	16	16	-	12	
Minimum Travelway Width (ft.) (one-way road)	12	12	12	-	12	
Shoulder Width (each side, two-way road) (ft.)	6	4	2	-	-	
Shoulder Width (each side, one-way road) (ft.)	2	2	2	-	-	
Stone Base (ABC) Compacted (in.)	8	6	6	-	-	
Asphalt	(1½ of S-9.5B or BST)					
Cut and Fill Slope	2:1	1.5:1	1.5:1	-	-	
Ditch Slope	4:1	3:1	3:1	-	-	
Vertical Clearance (ft.)	13.5	13.5	13.5	13.5	13.5	

§200A-99. Additional Road Design Standards Applicable to all Road Classifications.

- A. Intersections. Acceptable angles of intersection are:
- (1) 90 to 75 degrees (preferred)
 - (2) 75 to 60 degrees (acceptable under extreme conditions as determined by the reviewing agency).
- B. Adequate Sight Distances. Adequate sight distances (see Figure 3A. Sight Visibility Triangle) along a proposed road shall be provided by:
- (1) Choosing a good location for the *right-of-way* and clearing *sight visibility triangles* when constructing the road (the minimum sight distance is 70 feet along

the “existing” *road right-of-way* and ten (10) feet along the “new” *road right-of-way*).

- (2) Providing an adequate place for *vehicles* to stop before entering the *road*.
- (3) Providing an apron design at proposed intersections to permit a *vehicle* to enter when another *vehicle* is waiting to turn.

Figure 3A. Sight Visibility Triangle

Not to Scale

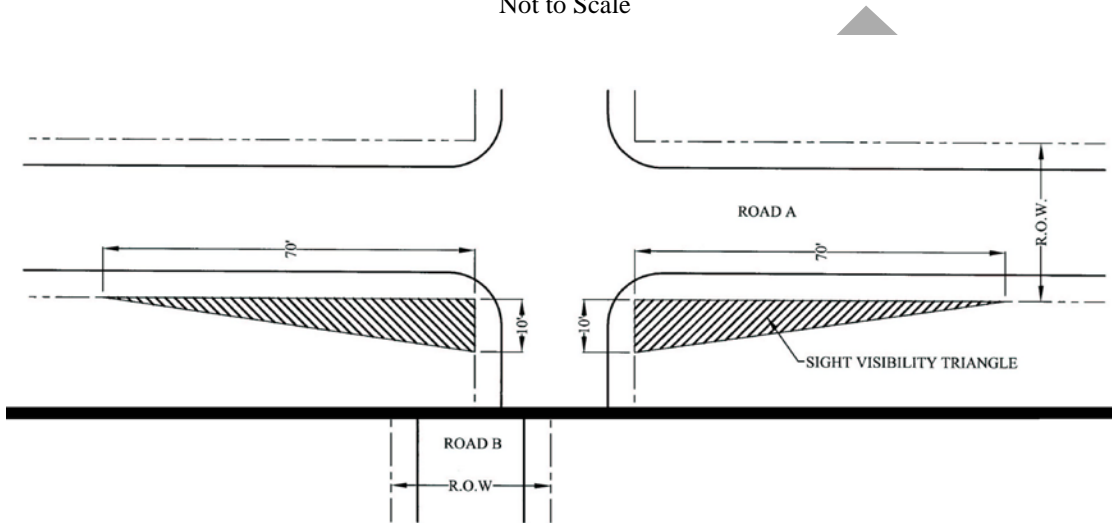

- C. Gates. *Entry gates* shall be constructed and maintained as required by and in accordance with Chapter 89 of the Henderson County Code, *Entry Gates*, and SR 3.7 (Gates and/or Guardhouses).
- D. Dead Ends, Cul-de-sacs and Turnarounds. *Vehicle* turnaround areas shall be provided at the end of all dead-end *roads* that exceed 300 feet. Loop *roads* should be encouraged where possible in lieu of culs-de-sac or turnarounds. The reviewing agency may also require installation of turnarounds at:
 - (1) Intermediate locations along dead end *roads* with a centerline length of greater than 2,500 feet.
 - (2) The end of a *phase* of a project.
 - (3) An intermediate location along any *road* that exceeds 1,500 feet in length.

Acceptable alternative turnaround designs for residential *subdivisions* are shown in Figures 3B, 3C, and 3D. Turnaround areas of a dead-end *road* cul-de-sac shall have a radius of not less than 35 feet.

Figure 3B. Alternative Turnaround Design – Island

Not to Scale

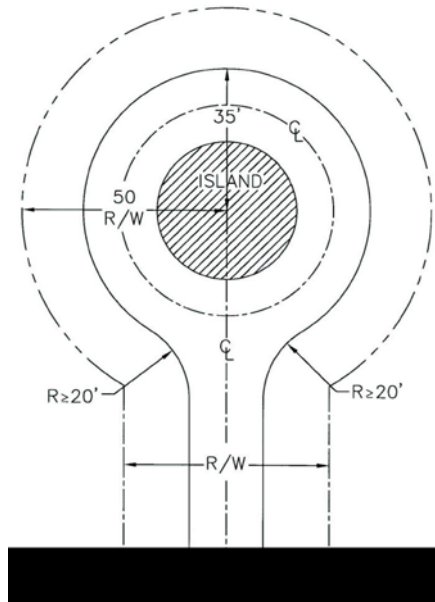

Figure 3C. Alternative Turnaround Design – Branch Turnaround
Not to Scale

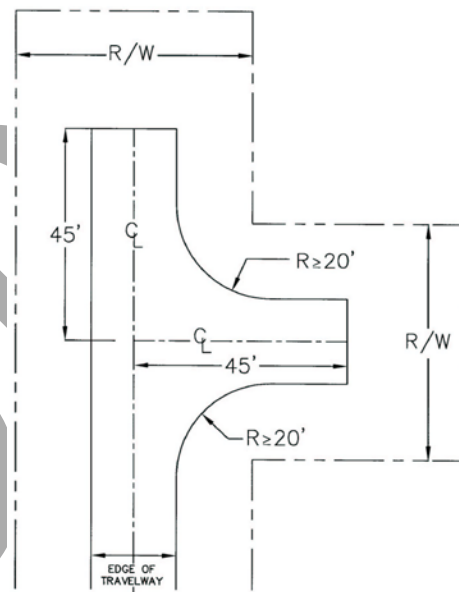
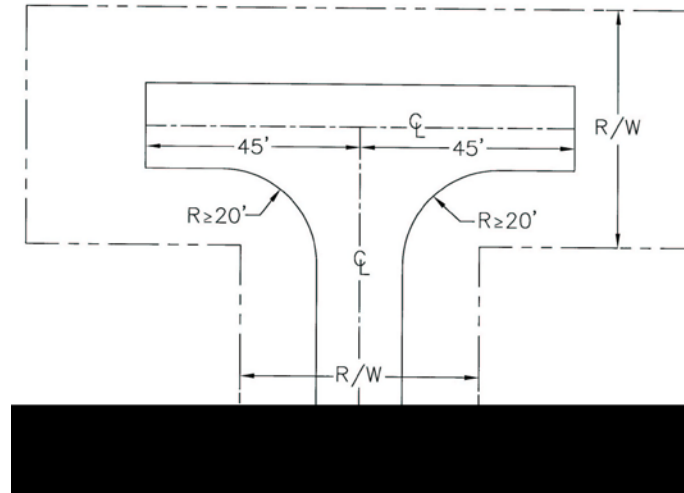

Figure 3D. Alternative Turnaround Design – T Turnaround
Not to Scale



F. Bridges. Bridges shall:

- (1) Be engineered to a minimum weight capacity of 50,000 pounds (For purposes of emergency management *vehicle* access) and documentation shall be provided to indicate such (the 50,000 pound weight capacity requirement shall not apply to *driveways*);
- (2) Adhere to *State Road Standards* for drainage, hydraulics and minimum live load;
- (3) Adhere to standards for *vertical clearance* for roads (See Table 3.3);
- (4) Provide a *travelway* width not less than the *travelway* width of the *road* on either side of the bridge, and in no case less than 12 feet in width;
- (5) Include a paved or gravel turnout on each end of the bridge to provide space for at least one (1) vehicle to safely pull over and allow an oncoming vehicle to traverse the bridge where the *travelway* width is less than 18 feet and is proposed to accommodate two-way traffic; and
- (6) Provide adequate line-of-sight distances for safe operation of two-way traffic.

§200A-100. Private Road Standard Reductions.

- A. Right-of-way Width Reduction.** Right-of-way width requirements may be reduced to 30 feet in width where no more than four (4) lots are proposed and it is unlikely (due to design, topographic conditions or existing development) that any road contained therein would be extended to serve more than four (4) lots.

Right-of-way width reductions are also permitted where the development is a *dwelling, multifamily, five (5) or more units*, provided these modifications are approved by the reviewing agency with consideration to sound engineering, public safety concerns and community character.

- B. Travelway Width Reduction.** Travelway width requirements for *private subdivision limited local roads* in special *subdivisions* may be reduced to nine (9) feet where an existing road with a travelway width of at least nine (9) feet occurs. The *Subdivision Administrator* will permit the reduction only upon inspection for road stability and

provided that all other *private subdivision limited local road* standards are met. Existing roads shall be improved to meet the *private subdivision limited local road* standards before a *final plat* can be approved.

C. Centerline Curve Radius Reductions. Centerline curve radius reductions may be reduced to:

- (1) 80 feet where the existing cross slope on *private subdivision collector roads* is 15 percent or greater, or
- (2) 60 feet where the existing cross slope on *private subdivision limited local residential subdivision roads* or *private subdivision local residential subdivision roads* is 15 percent or greater.

Centerline curve radius reductions are also permitted where the development is a *dwelling, multifamily, five (5) or more units*, provided these modifications are approved by the reviewing agency with consideration to sound engineering, public safety concerns and community character.

D. Shoulder Width Reduction. Shoulder width shall be reduced for:

- (1) *Private subdivision local roads* and *private subdivision collector roads* to a minimum of two (2) feet in cases where the existing cross slope is 20 percent or greater; and
- (2) *Private subdivision collector roads* to a minimum of four (4) feet in cases where the existing cross slope is greater than ten (10) but less than 20 percent or greater.

E. Cut and Fill Slopes. Cut and fill slopes shall be reduced to 1:1 where the existing cross slope is 20 percent or greater.

Subpart D. Subdivisions Standards by Type.

§200A-101. Nonstandard Subdivisions

Nonstandard subdivision *lots* shall:

- A. Be exempt from the density requirements of this Chapter.
- B. Include *special use lots* (the *structures* located thereon must meet any applicable zoning or *water supply watershed* requirements) clearly identified for a designated use.
- C. Be identified and encumbered to its specified use on a *final plat*.
- D. Be provided with a platted or deeded right-of-way that connects each proposed *lot* and remainder parcel to a public *road*.
- E. Not be counted in the number of *lots* in a *subdivision* for administrative purposes.

§200A-102. Special Subdivisions (Five (5) or Fewer Lots).

Where there is insufficient acreage to meet the density regulations of the zoning districts, up to five (5) lots may be created where each lot is at least one half (1/2) acre (21,780 square feet in size).

§200A-103. Minor Subdivisions (Six (6) to Ten (10) Lots)

Minor subdivisions shall adhere to all applicable requirements of this Chapter.

§200A-104. Major Subdivisions

A. Subdivisions of 35 or More Lots.

- (1) Shall provide a minimum of two (2) entrance *roads*. (The second entrance requirement must be specifically waived by the approving authority, and only where unique circumstances (including severe topographic conditions, the presence of *unique natural areas*, existing development patterns, or other limiting site conditions) would prevent the addition of a second entrance.)
 - (2) No more than 35 *lots* within a *subdivision* shall be accessed by a dead-end *road*, cul-de-sac or turnaround or a series of dead-end *roads*, cul-de-sacs or turnarounds to access the main entrance(s)/exit(s) for the *subdivision* (except where a stub *road* is proposed as a future connection (however, stub *road* proposals do not entitle adjoining property owners access to the *subdivision*).
- B. Soil Erosion and Sedimentation Control Plan. The applicant must provide written notice from:
- (1) The appropriate state and/or local agencies verifying an Erosion and Sedimentation Control Plan has been received, or
 - (2) A professional land surveyor, engineer, landscape architect, architect, or professional planner certifying no plan is required.

Developers should not disturb and clear more land than needed for infrastructure and other *subdivision* related improvements.

C. Water Supply System and Sewage Disposal System Required. Every *lot* shall be served by a *water supply system* and *sewage disposal system* adequate to accommodate the reasonable needs of the proposed *use* and comply with all applicable health regulations. The *applicant* must provide evidence that *water supply system* and *sewage disposal system* plans have received final approvals by the appropriate agency prior to *final plat* approval (except as noted in item B(1) below).

(1) Individual Water Supply and Sewer Systems (Well and Septic Tanks). Where the *water supply system* and/or *sewage disposal system* to be installed is an individual system for each *lot*, the installation of said systems will not be required prior to *final plat* approval.

Where a *subdivision* is located entirely or partially in those areas designated as Rural (RAA) in the *Comprehensive Plan*, the *applicant* shall adhere to one (1) of the following two (2) options:

- a. Community Well System. Provide a community well system (a type of *public water supply system*) that meets State standards for *public community water systems* (individual wells shall not be permitted in this situation). The location of each well and the waterlines shall be shown on the development plan. If the locations of the well(s) or waterlines change, the *applicant* shall submit a revised development plan. The distribution system (waterlines) is not required to be constructed and installed prior to beginning land disturbing/construction activity or any other improvements.
- b. Individual Wells (not recommended). The *applicant* shall provide reasonable documentation demonstrating there is sufficient water supply to support 60 percent of the proposed *lots*. The location of each well shall be shown on the development plan.

The *applicant* shall provide documentation for either Option a or Option b prior to beginning any land disturbing/construction activity or any other improvements not associated with the installation of the well or wells.

(2) Municipal Water Supply Systems and Municipal and Approved Public or Community Sewage Disposal System Requirements. Where a *municipal water supply system* or *municipal sewage disposal system* is/are proposed, a letter from the respective agency/agencies stating there is sufficient capacity to a make connection to the system(s), must accompany the *subdivision* application.

All *public water supply systems*, *municipal sewage disposal systems*, and *approved public or community sewage disposal systems* shall be installed and shall meet the requirements of the local or State authorities having jurisdiction thereof.

(3) Required Connection to a Municipal Water Supply System and Municipal Sewage Disposal System. The approving authority may require a *subdivision* of 300 or more units connect to a *municipal water supply system* if located within two (2) miles of an existing *municipal water supply system*. If a subdivision is within

5,000 feet of an existing *municipal water supply system* and the distance is equal to or less than the product of 100 feet multiplied by the number of proposed *lots*; the subdivision shall be required to connect to the municipal water supply system.

The Approving Authority may require a *subdivision* of 300 or more units connect to a *municipal sewage disposal system* if the *subdivision* is located within one (1) mile of an existing *municipal sewage disposal system*. If a subdivision is within 2,500 feet of an existing *municipal sewage disposal system* and the distance is equal to or less than the product of 50 feet multiplied by the number of proposed *lots*, the subdivision shall be required to connect to the *municipal sewage disposal system*.

No *subdivision* located within those areas designated as Rural (RAA) in the *Comprehensive Plan*, shall be required by the approving authority to connect to a *municipal water supply system* or *municipal sewage disposal system*.

Required connects may be provided exception on the basis of terrain, availability of acquiring *easements*, denial of allocation by the public utility, insufficient capacity of the municipal system or other circumstances unusual or unique to the site. Requests for exceptions must be made, in writing, to the *Subdivision Administrator* who may require that such requests be supported by a professional engineer's review of the *subdivision* plans and planned route of the utility extension. If the *Subdivision Administrator* determines that it would not be economically feasible for a *subdivision* to be connected to a *municipal water supply system* or *municipal sewage disposal system*, another system may be used, subject to approval by the appropriate agencies.

(4) Fire Protection Requirements. Either:

- a. Install a minimum of one (1) hydrant per 1000 feet of linear *road* distance (if served by a *public water supply system* who may impose more stringent *fire protection* requirements where necessary): or
- b. Install a dry fire hydrant system (the type and location of which is to be determined by the County Fire Marshal) and all-weather access *road* for fire-fighting equipment to a permanent surface water supply (minimum 100,000 gallon storage in a 50 year drought).

If the *subdivision* is neither served by a *public water supply system* nor has or is adjacent to an adequate permanent surface water supply it shall be thoroughly reviewed by the reviewing agency and *applicant* to determine if alternative measures to ensure adequacy of *fire protection* exist. Where deemed necessary and without creating an undue hardship on the *applicant*, the reviewing agency may require the *applicant* to install alternative *fire protection* measures.

- D. Stormwater Drainage. Drainage systems (swales, ditches, pipes, culverts, detention ponds, lakes or similar devices) shall be designed to minimize adverse effect on the proposed *subdivision* and on adjacent and downstream properties. Drainage improvements shall be designed and constructed in accordance with applicable *State Road Standards* and to:

- (1) Follow natural drainage (where possible),
 - (2) Contain points of stormwater discharge onsite (unless offsite discharge is approved by the reviewing agency and adjoining property owners),
 - (3) Maintain desirable groundwater conditions,
 - (4) Minimize *erosion*, downstream *sedimentation*, flooding or standing water conditions,
 - (5) Filter pollutants before stormwater reaches surface water, and
 - (6) Avoid excessive stormwater discharge.
- E. Farmland Preservation District Setback. A minimum 100 foot *setback* for all *buildings* or *structures* is required from any Farmland Preservation District (marked on official maps maintained by the Henderson County Soil and Water Conservation District). *Subdivisions* located adjacent to a Farmland Preservation District should be developed using 5200A-80 Conservation Subdivision Standards.
- F. Reasonable pedestrian access shall be provided to promote healthy and safe walking environments.
- (1) Pedestrian facilities (sidewalks and/or walking trails) shall be:
 - a. 100 or more *lots* or
 - b. A *density* equal to or greater than two (2) units per acre
 - (2) Provide one (1) linear foot of sidewalk or walking trail for every linear foot of improved or newly proposed roadway within the tract.
 - (3) Located in a *road right-of-way*, pedestrian access *easement*, or other dedicated *open space*.
 - (4) Five (5) feet in width or more.
 - (5) Constructed (sidewalks only) with concrete, asphalt, or other permanent all-weather surface such as gravel.
- The location and design of such facilities shall be approved by the reviewing agency. The maintenance and expansion of pedestrian facilities will fall under the authority of the homeowners' association, which must be established where pedestrian facilities are required.
- G. Street Tree Requirements. Street trees shall be required in accordance with Article V (Landscape Design Standards) Subpart C (Street Tree Requirements).
- H. Subdivision Setback and Buffering. When a *tract* to be *subdivided* is located outside a *Comprehensive Plan* designated Community Service Center Node and within a residential zoning district, the following shall be required:
- (1) A 50 foot *structure setback* from any *external road* which is not classified as a *local road*, with the understanding that *lots* may be created which contain all or portions of the *setback*.

(2) Installation of a B2 *buffer* (see Article V (Landscape Design Standards) Subpart A (Buffer Requirements)) within the required setback where the *tract* is located along a: *collector road, thoroughfare, boulevard, expressway or freeway*. The *applicant* should, where possible, maintain existing stands of trees in accordance with §200A-153 (Credits for Preserving Existing Trees) to meet this standard.

- I. Air Quality. As required by NCGS Chapter 143, Article 21, all *subdivisions* shall show proof of compliance, if applicable, with air quality guidelines established by the Division of Environmental Management and NCDENR.

§200A-105. Affordable Housing Subdivisions (Reserved)

Subpart E. Subdivision Improvement Guarantees

§200A-106. General

Where the required improvements have not been completed, prior to the submission of the *final plat* for approval, the approval of said *plat* shall be subject to the *applicant* guaranteeing the installation of the improvements within two (2) years provided the following:

- (1) A minimum of 50 percent of the required improvements (based on total project cost that the applicant is guaranteeing) is in place. The required improvements shall include rough grading for all proposed roads that are part of said *improvement guarantee*.
- (2) All associated local, state and federal permits for the development must be approved and a copy of said approval has been provided to the *Subdivision Administrator* (includes any required Army Core permits, stream or wetland mitigation fees/permits, water or sewer treatment plant permits and design schematics for infrastructure completed and received for these applicable approvals).
- (3) All associated design plans and construction specifications for the required improvements (i.e. roads, bridges, water and sewer infrastructure, stormwater infrastructure, pedestrian infrastructure, etc.) are submitted to the *Subdivision Administrator*.

§200A-107. Cost Estimate Standards

Plans, specifications, quantities, unit costs and estimated total costs shall be provided by the *applicant* to the *Subdivision Administrator*. Cost estimates shall:

- A. Be prepared by a professional engineer, professional land surveyor or landscape architect at the *applicant's* expense.
- B. Provide a schedule for initiation and completion of work.
- C. Include separate estimates for roads, bridges, water and sewer infrastructure, stormwater infrastructure, pedestrian infrastructure, etc. consistent with submitted design plans construction specifications.

- D. Include all associated fees for remediation work required for the proposed improvements (unless proof of payment for remediation fees is provided to the *Subdivision Administrator*).

§200A-108. Improvement Guarantee Instrument

The *applicant* shall guarantee the installation of such improvements by either of the methods described below:

- A. Filing a performance or surety *bond* or an irrevocable standby letter of credit in the amount of **150 percent** of the cost to complete the work as determined by cost estimates. Portions of the guarantee may be released as work progresses.
- B. Depositing or placing in escrow a certified check or cash in an amount equal to **150 percent** of the cost to complete the work as determined by cost estimates amount. Portions of the guarantee may be released as work progresses provided a new cost estimate is provided detailing the work that has been completed and that is remaining.

§200A-109. Amount and Terms of Guarantee, Time Limits and Extensions

- A. Approval. All guarantees shall be accompanied by a written agreement (performance agreement) specifying the terms and the amount of the guarantee. The *Planning Director* shall have the authority to approve all improvement guarantee applications taking into consideration the amount and terms of the guarantees for improvements (including time of initiation and completion of the work).
- B. Amount and Terms. The amount of the guarantee shall be sufficient to provide adequate funds to the County to ensure, in the case of default, the installation of all required improvements uncompleted at the time of default. All *improvement guarantees* shall comply with applicable statutory requirements and shall be satisfactory to the County Attorney or Staff Attorney as to form, sufficiency and manner of execution. Guarantees employing lending institutions shall require that those banking corporations be licensed to do business in North Carolina **and be from a national association or FDIC registered group**.

The following terms shall be stated in the performance agreement:

- (1) The applicant shall be provided 15 days to identify a new security provider or prove alternate security where the security provider is in default, bankruptcy, or otherwise determined to be insolvent by the County after which time the County may call the improvement guarantee.
- (2) The applicant shall provide the County with specific benchmarks for completion of work and, as a term of the agreement, should the applicant fail to meet the self-imposed benchmarks the County may call the improvement guarantee.
- (3) If in violation of any other provision of this Chapter 200A, Henderson County Land Development Code, where the applicant has been notified of the violation, and the applicant has been provided the period for remediation authorized by the approving agency, and where applicant is in continued violation, the County may

consider this to be a breach of the agreement and call the improvement guarantee to prevent further violation of Chapter 200A, Land Development Code.

- C. Time Limits. The *improvement guarantee* is valid for a period of one (1) year from the date of execution.
- D. Extensions. The *Planning Director*, upon proof of difficulty, may grant an extension for a maximum of one (1) additional year. Improvements not completed within two (2) years shall be in breach with the requirements of this section and the *improvement guarantee* and any and all monies and accrued interest shall be forfeited by the *applicant*.
- E. Second Improvement Guarantee. If the *Planning Director* has found that the *applicant* has made a good faith effort in completing the required improvements within the two (2) years, the County may allow the *applicant* to execute a second *improvement guarantee*. Said agreement must be in the form of cash on deposit equal to 150 percent of the cost of the remaining improvements. The County shall assess an administrative fee equal to ten (10) percent of the new *improvement guarantee* monies.

§200A-110. Violations and Penalties

If an *applicant* of a *subdivision* is in violation of any County regulations (including Soil Sedimentation and Erosion Control Permits) the County will not release the *improvement guarantee* prior to the expiration date unless the violations are corrected.

The County may charge for the cost for construction and project administration for any *improvement guarantee* that is executed.

Subpart F. Application, Enforcement and Legal Status Provisions

§200A-111. Designation of Agent

The *applicant* for any *subdivision* review or approval procedure may submit, along with any initial application, an affidavit specifying an agent who may represent the *owner* in all matters.

§200A-112. Approval Prerequisite to Plat Recordation

Pursuant to NCGS §153A-331, and except where otherwise provided in this Chapter, no *final plat* of a *subdivision* within the jurisdiction of this Chapter shall be recorded by the Register of Deeds of Henderson County until it has been approved by the *Subdivision Administrator*, Technical Review Committee, or Planning Board as provided herein. The Register of Deeds shall not file or record a *plat* of the *subdivision* of land, any part of which is located within the jurisdiction of this Chapter that has not been approved in accordance with these provisions. In addition to meeting the requirements of this Chapter, *subdivisions* proposed within designated *water supply watershed* areas shall be subject to the provisions of the *Water Supply Watershed* Protection requirements of this Chapter, and the *Water Quality Administrator* or his designee shall certify on such *plats* that the *subdivision* complies with the provisions of the *Water Supply Watershed* Protection requirements of this Chapter.

§200A-113. Certification of Exemptions

Any *plat* of property exempted from the regulations of this Chapter shall be certified by the *Subdivision Administrator* or a professional land surveyor as exempt, prior to such *plat* being recorded. Such *plat* is not exempt from the other requirements set forth in this Chapter or any other local ordinances. Pursuant to NCGS §47-30 (f) 11 (Duty of the Surveyor), a professional land surveyor may certify that such *plat* represents an exception to the definition of *subdivision* and is not subject to the provisions of this Article. Such *plat* may be recorded without being certified by the *Subdivision Administrator*. Any exemption from the regulations of this Chapter shall not be deemed an exemption from any other applicable ordinance. Any court-ordered *subdivision* should comply, to the maximum extent possible, with the provisions of this Chapter.

§200A-114. Plat Approval Required for Building Permit

No building permit may be issued for any construction on any proposed *lot* shown on a development plan until a *final plat* has been approved and recorded, except that a building permit may be issued for one (1) *structure* on one (1) *lot* shown on any approved development plan prior to recordation of a *final plat*. The Building Services Department shall deny building permits for *subdivision lots* created in *violation* with the terms and conditions of this Chapter.

§200A-115. Land Auctions

Where application for *major* or *minor subdivisions* is made with the intent that such divided property will be sold at land auction, the *final plat* shall clearly state the following: "The property herein is to be sold by auction. Any further *subdivisions* must meet applicable standards set forth in the Henderson County Land Development Code." In addition, restrictive covenants regarding *road* maintenance for any dedicated *rights-of-way* must be approved in advance by the appropriate reviewing agency and recorded prior to such auction.

§200A-116. Limitation on Applications Pending

Only one (1) application for a *subdivision* may be reviewed by any reviewing agency at any one (1) time on any of the original property boundaries. An application is only valid for up to one (1) year after its submission to the Planning Department. Applications submitted over one (1) year prior must be updated and resubmitted.

§200A-117. Violations and Penalties

If an *applicant* of a *phased minor* or *major subdivision* is in *violation* of any regulation in Article III (Subdivision Regulations) for the first *phase* of the *subdivision* then the *applicant* will not be allowed to continue developing future *phases* of the *subdivision* and any County issued permits may be revoked or suspended by the County. Upon verification by Henderson County Planning Staff that the *subdivision* no longer violates the provisions of Article III, *subdivision* approval and any suspended permits will become valid. The *applicant* may reapply pursuant to applicable provisions of the Land Development Code to have any revoked permits reinstated.

Non-subdivision Related Text Amendments
(LDC 2010 Annual Text Amendments (TX-2010-02))

LDC Text Amendment 1: CCP Amendments.

Issue: The general statutes do not have specific requirements for adopting or amending comprehensive plans. The existing LDC standards for CCP amendments are set forth by County policy, and require the County to hold a public hearing to take action on non-administrative amendments. Existing LDC standards also require a published notification.

The proposed amendment would allow the Board of Commissioners to hold a public hearing on any CCP amendments, but not require it based on state statutes. The amendment would also require the County to file proposed amendments with the clerk to the Board of Commissioners and post on the County website at least 10 but not more than twenty-five days prior to the Commissioners taking action on the proposed amendment (this is an additional requirement from current standards). The amendment would remove the required published notice and allow the Board of Commissioners the option of mailing notices to affected property owners.

This will greatly reduce the cost of published notices and will allow the Commissioners the flexibility to amend the CCP where deemed appropriate while adding additional provisions for notifying the public and affected property owners via the website and mailed notices (when appropriate).

Recommendation: Amend the public notification and public hearing requirements for non-administrative amendments to the CCP.

Comprehensive Plan Amendments

- (4) Public Notification. ~~Notice of proposed change must be filed with the clerk to the Board of Commissioners and posted on the County website at least ten (10) but not more than twenty-five (25) days prior to the Commissioners approving proposed amendments. Where deemed appropriate, notices may be mailed to affected property owners. Public notification of such hearing shall comply with the provisions of NCGS §153A-323 and §153A-343, as amended (See §200A-338 (Legislative Process Standards)). Planning Staff shall be responsible for all necessary public notifications.~~
- (5) Public Hearing. None required. ~~The Board of Commissioners may hold a public hearing on the amendment(s). Prior to amending the Comprehensive Plan substantively, the Commissioners shall hold a public hearing on the amendment(s) in accordance with NCGS §153A-323, as amended (See §200A-338 (Legislative Process Standards)).~~

LDC Text Amendment 2: Family Cemetery.

Issue: The Cemetery Advisory Committee had requested adding family cemeteries to the permitted use table and had recommended specific standards and setback requirements for this type of use.

Recommendation: Add family cemeteries as a permitted use in all residential zoning districts with standards (SR 5.3).

USE TYPE	GENERAL USE DISTRICT											
	P=Permitted; S=Special Use Permit											
	R1	R2	R2R	R3	R4	OI	MU	LC	CC	RC	I	SR
5. EDUCATIONAL AND INSTITUTIONAL USES												
Cemetery, Family	P	P	P	P	P							5.3

SR 5.3. Cemetery, Family

- (1) Site Plan. Major *Site Plan* required in accordance with §200A-299 (Major Site Plan Review).
- (2) Plot Setback. Plots shall be:
 - a. Fifty (50) feet from any property line.
 - b. One hundred (100) feet from any structure.
 - c. One hundred (100) feet from an existing well.
 - d. One hundred (100) feet from the high-water mark of any spring, stream, lake, reservoir or other know source of water. Family cemeteries shall not be located in *a special flood hazard area*.
- (3) Security. The family cemetery shall be enclosed by a fence or wall at least four (4) feet in height.
- (4) Certification, Licensure and Permitting. A family cemetery shall comply with all applicable local, state and federal environmental and public health laws (including the requirements of N.C.G.S. 65-Cemeteries). Construction of a mausoleum, columbarium, or any monument or other grave marker shall comply with all applicable state building code requirements.
- (5) Deed of Record. A family cemetery shall be described by metes and bounds and recorded in the Register of Deeds office.
- (6) Responsibility. The owner of any property which contains all or part of a family cemetery is responsible for maintaining the family cemetery in compliance with local, state and federal regulations.

LDC Text Amendment 3: Accessory Structure Setbacks.

Issue: Accessory structures are currently allowed in all zoning districts provided the structures are setback a minimum of 10 feet from side and rear property lines.

The proposed amendment would reduce the side and rear setback to 5 feet for accessory structures. This setback would still meet the of N.C. State Building Code standards which require a 10 foot separation between structures. This amendment would not permit accessory structures in the front yard (existing LDC standard) and would not allow for a reduction in setbacks for the R-40 and WR zoning districts (these zoning districts have specific standards for accessory structures/uses).

Recommendation: Reduce the side and rear setback for accessory structures to 5 feet (complies with 10-foot state building code separation) for all zoning districts excluding the R-40 and WR districts.

LDC Text Amendment 4: Dumpster(s).

Issue: The LDC does not have a provision to allow dumpsters as an accessory use. Certain non-residential uses require a solid waste collection system and allow for the use of dumpsters (with

standards). This amendment adds dumpsters as an accessory use with similar standards stated in the LDC for certain non-residential uses that require solid waste collection.

Recommendation: Add dumpsters as an accessory use (for non-residential and multi-family residential uses) permitted in all zoning districts with standards (SR 2.3).

USE TYPE	GENERAL USE DISTRICT P=Permitted; S=Special Use Permit												
	R1	R2	R2R	R3	R4	OI	MU	LC	CC	RC	I	SR	
2. ACCESSORY USES													
Dumpster(s)	P	P	P	P	P	P	P	P	P	P	P	P	2.3

SR 2.3. Dumpster(s)

- (1) Associated Principal Use. Dumpsters are allowed as an accessory use to a non-residential or multi-family residential use.
- (2) Operations. The use of dumpsters shall be installed and/or operated to meet all local and state statutes, ordinances and regulations (including Chapter 165 of the Henderson County Code, Solid Waste).
- (3) Screening. Screen Class One (1), Two (2) or Three (3) shall be provided consistent with the requirements of §200A-150 (Screen Classification).
- (4) Location. The *Zoning Administrator* may require the dumpster(s) to be located on concrete pads designed to drain to a bio-retention area to filter *stormwater* before the water reaches a larger drainage system.

LDC Text Amendment 5: Corrections to Decision Making, Administrative and Advisory section.

Issue: Staff identified corrections that needed to be made to the Decision Making, Administrative and Advisory section of the LDC. These corrections included amending the authority of the Board of Commissioners (BOC), Planning Board, Zoning Board of Adjustment (ZBA) and Flood Damage Prevention Board to reflect existing review processes.

This amendment clarifies that the ZBA (which also acts as the Flood Damage Prevention Board) hears all quasi-judicial proceedings and does not have the authority to defer these hearings to the BOC. The amendment also removes the special intensity allocation power since this use was removed with recent stormwater amendments.

Recommendation: Correct the Decision Making, Administrative and Advisory section of the LDC.

Henderson County Board of Commissioners

- ~~(9) Special Use Permits. To grant special use permits deferred by the Zoning Board of Adjustment as authorized by this Chapter.~~
- ~~(10) Special Fill Permits. To grant special fill permits as authorized by this Chapter.~~
- ~~(11) Special Intensity Allocation. To grant special intensity allocations as authorized by this Chapter.~~

Henderson County Planning Board

- (7) Special Fill Permits. To review *special fill permit* applications and make recommendations to the ~~Board of Commissioners~~ **Flood Damage Prevention Board** for final action thereon.

Henderson County Zoning Board of Adjustment

- (7) Special Use Permits. To grant *special use* permits as authorized by this Chapter. ~~or to defer the decision to the Board of Commissioners;~~

Henderson County Flood Damage Prevention Board

- (4) Special Fill Permits. To grant *special fill permits* as authorized by this Chapter.

LDC Text Amendment 6: Plan and Permit Appeals for Soil Erosion and Sedimentation Control.

Issue: Existing LDC standards require the ZBA to hold a hearing on appeals for soil erosion and sedimentation control with 30 days after the date of the appeal or request for a hearing. The amendment would change the time limitations from 30 to 60 days to ensure that the ZBA can hear the appeal at its next regularly scheduled meeting without holding a special called meeting.

Recommendation: Amend the time limitation for the ZBA to conduct hearings for appeal for soil erosion and sedimentation control.

Plan and Permit Appeals

- (2) A hearing held pursuant to this section shall be conducted by the Henderson County Zoning Board of Adjustment (ZBA) within ~~60~~30 days after the date of the *appeal* or request for a hearing.

LDC Text Amendment 7: Quasi-judicial Proceedings.

Issue: The general statutes require government boards to hold a quasi-judicial proceeding for certain types of approvals such as: special use permits, vested rights, variances and appeals. Quasi-judicial proceedings require parties to be identified to speak during the hearing. The statutes require that parties be notified, but do not require further notification. LDC notification requirements are set forth by County policy but are not required by the state statutes.

The proposed amendment removes the newspaper notice requirement since it is costly to the County and is not required by the general statutes. The proposed amendment would require the property in question to be posted with notice of the hearing (this is not currently required).

Recommendation: Amend the newspaper notice for quasi-judicial proceedings and require a posted notice.

Quasi-Judicial Process Standards

- (1) Public Hearing. Before taking any action, the appropriate Zoning Board of Adjustment (ZBA) shall hold a public hearing (quasi-judicial) on the application, in accordance with established procedures for quasi-judicial hearings.
- (2) Newspaper Notice. ~~None required. The ZBA shall cause notice of such hearing to be published in a newspaper of general circulation in the County once a week for two (2) successive calendar weeks. The notice shall be published the first time not less than ten (10) days nor more than 25 days prior to the date fixed for the hearing. The notice shall include the time, place and date of the hearing and include a description of the property or the nature of the change or amendment to map. In computing such period, the day of publication is not to be included but the day of the hearing shall be included.~~

- (3) Mailed Notice. The *owner* of that parcel of land (related to the application) as shown on the County tax listing, and the *owners* of all parcels of land abutting that parcel of land as shown on the County tax listing, shall be mailed a notice of a public hearing on the proposed amendment by first class mail at the last addresses listed for such *owners* on the County tax abstracts. This notice must be deposited in the mail at least ten (10) but not more than 25 days prior to the date of the public hearing. The *person* or *persons* mailing such notices shall certify to the ZBA that fact, and such certificate shall be deemed conclusive in the absence of fraud.
- (4) Posted Notice. The County shall post one or more prominent *signs* on or immediately adjacent to the subject area reasonably calculated to give public notice of the hearing. In the event that more than one (1) parcel is involved, at least one (1) *sign* shall be posted in a central location; however, the *Zoning Administrator* may post multiple *signs*. Said *sign(s)* shall be posted at least ten (10) days prior to the hearing.

LDC Text Amendment 8: Small Outdoor Advertising Signs.

Issue: Outdoor advertising signs, no larger than 10 square feet, are currently permitted with standards as an exempt sign. Exempt signs do not require a zoning permit and thus the County has no record of these signs. Code Enforcement had requested that these small outdoor advertising signs be required to obtain a zoning permit and written authorization from the property owner so that the County can have a record for tracking these signs and ensure existing standards are being met.

This amendment would remove the outdoor advertising signs from the exempt provision to a permitted use section. The provisions for these small advertising signs would remain the same as found under the exempt section.

Recommendation: Add small outdoor advertising signs as a permitted use in the sign section.

Small Outdoor Advertising Signs.

Small outdoor advertising *signs* are permitted in all non-residential zoning districts with a zoning permit. All small outdoor advertising *signs* may have one (1) or two (2) faces (unless otherwise indicated). No *sign* shall be internally illuminated in excess of six (6) foot-candles (measured at ground level at any point within the property, and installed in such a manner that the source of light (the bulb) is shielded and not visible from adjacent roadways).

- (1) Maximum Area. Ten (10) square feet per face.
- (2) Maximum Height. Five (5) feet.
- (3) Permitted Districts. Permitted in all districts except *residential zoning districts* provided:
 - a. The applicant gets written authorization from the property owner for placement of the sign on the County prescribed form, and;
 - b. The sign complies with the standards set forth in §200A165 (Prohibited Signs) and §200A-167 (Sign Placement).