

## REQUEST FOR BOARD ACTION

### HENDERSON COUNTY BOARD OF COMMISSIONERS

**MEETING DATE:** August 12, 2008

**SUBJECT:** Board Room Desk Modifications

**ATTACHMENTS:**

1. Summary of Options
2. Option #3 and Quote

**SUMMARY OF REQUEST:**

At your June 2, 2008 meeting the Board reviewed a proposal (Option #1 on the summary sheet) to modify the Commissioners' existing desks adding 2 desks, incorporating 6" spacers between the desks to add workspace, adding a fixed shelf in the kneewells of the desks and providing a recess for the 17" monitors that the Board was previously using at that time.

After hearing the Board's concerns with that option, staff requested additional quotes and designs. Option #2 modifies the existing desks by carving away additional knee space. It also adds 2 desks, but does not provide a shelf or additional workspace on top of the desk for "elbow room".

Option #3 plans, which are being provided in detail with this agenda item, provides for complete reconstruction of the desk units. In addition, it provides 1 additional desk unit, additional workspace, space for recessing the 8" monitors, and provides space for a shelf underneath. The only area of concern with this option is that the depth of the drawer/shelf doesn't appear to provide enough space to slide the Board's existing chairs under the units.

Funds are available for this project within the Historic Courthouse Capital Project Fund.

**BOARD ACTION REQUESTED:**

Staff recommends that the Board approve Option #3 and directs staff to work with the vendor to modify the design in order to better accommodate the desk chairs.

**Suggested Motion:**

*I move that the Board approve Option #3 and direct staff to move forward with this project and work with the vendor to modify the design in order to better accommodate the desk chairs.*

# COMMISSIONERS DESK MODIFICATIONS OPTIONS

As of June 29, 2008

## Option #1

- Presented to the Board on June 2, 2008
- Modifies existing desk units
- Adds 2 additional desk units
- Adds 6" spacers between desk units
- Adds fixed shelf to kneewells
- Recesses 17" monitors into desk units

Quote: \$20,123

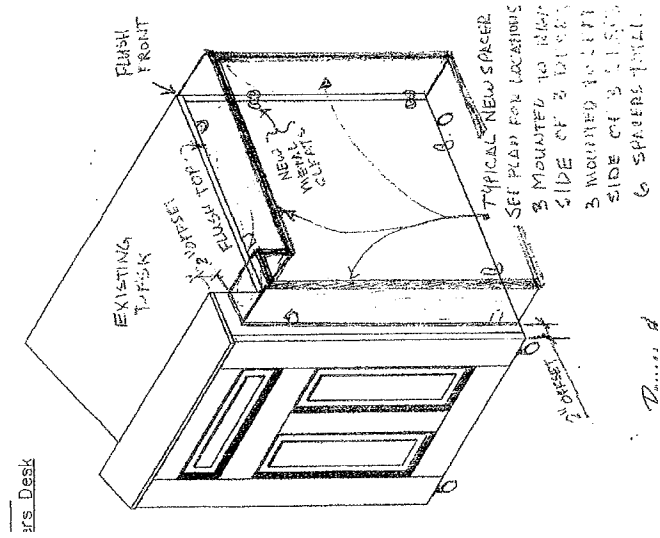

## Option #2

- Modifies existing desks
- No additional spacers between desk units
- No shelving added
- No recessing for monitors
- Adds 2 additional desk units
- Cuts kneewells to allow for more leg room
- Relocates casters

Quote: \$11,680

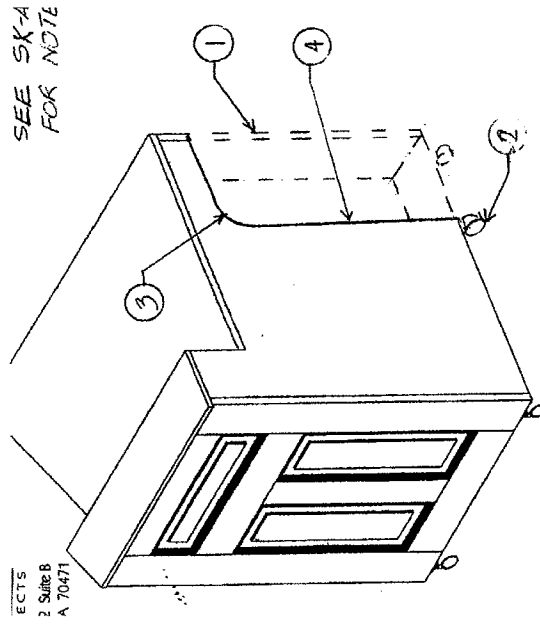

## Option #3

- Complete reconstruction of desk units
- Adds space for 1 additional desk unit
- Increases individual unit spaces by 5"
- Adds 1 drawer to each desk unit
- Recesses current 8" monitors

Quote: \$11,544

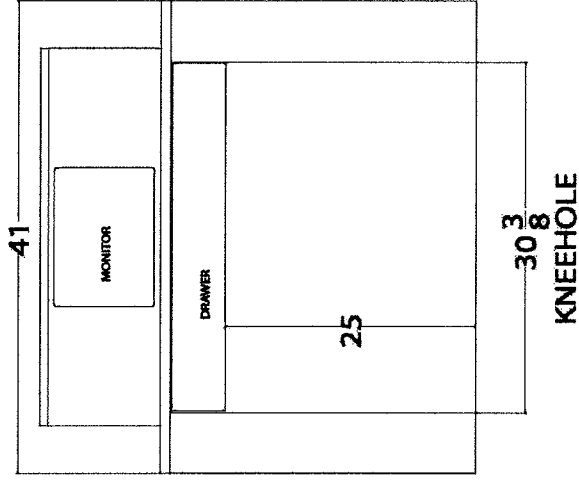

OPTION 3

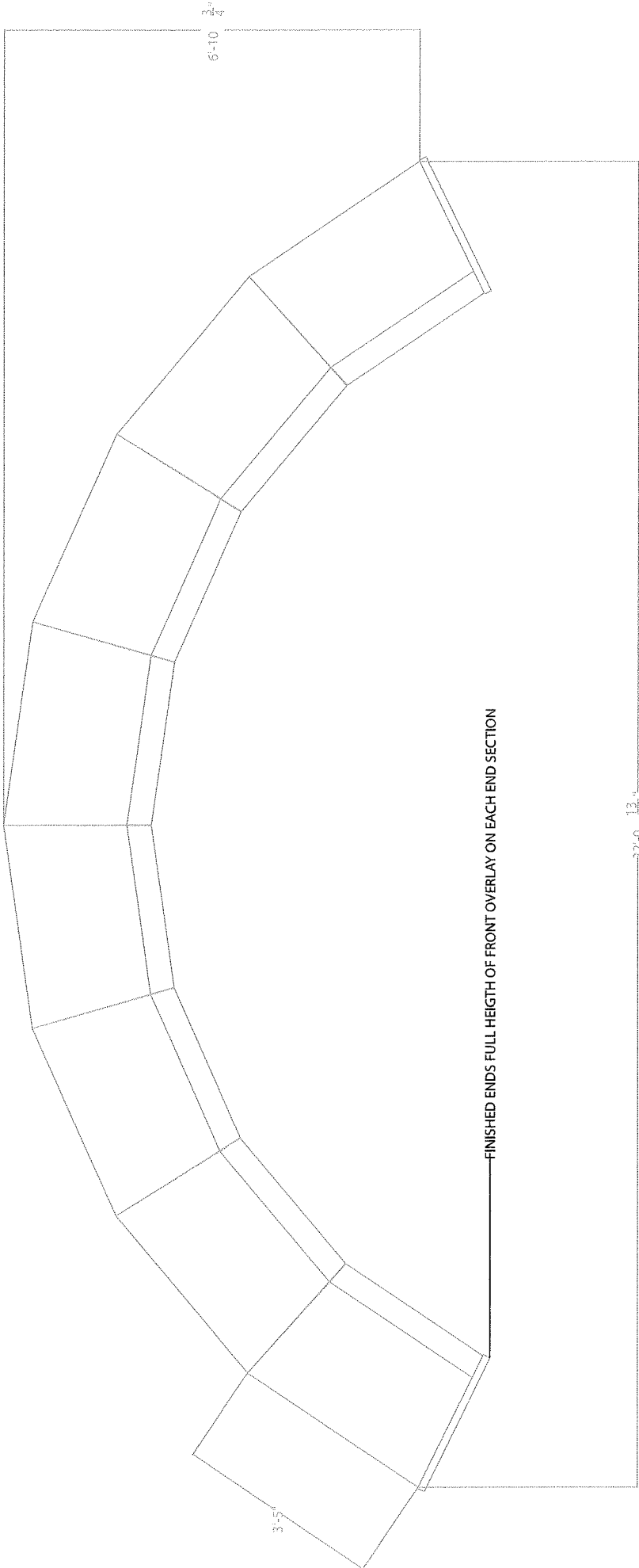

OPTION 3



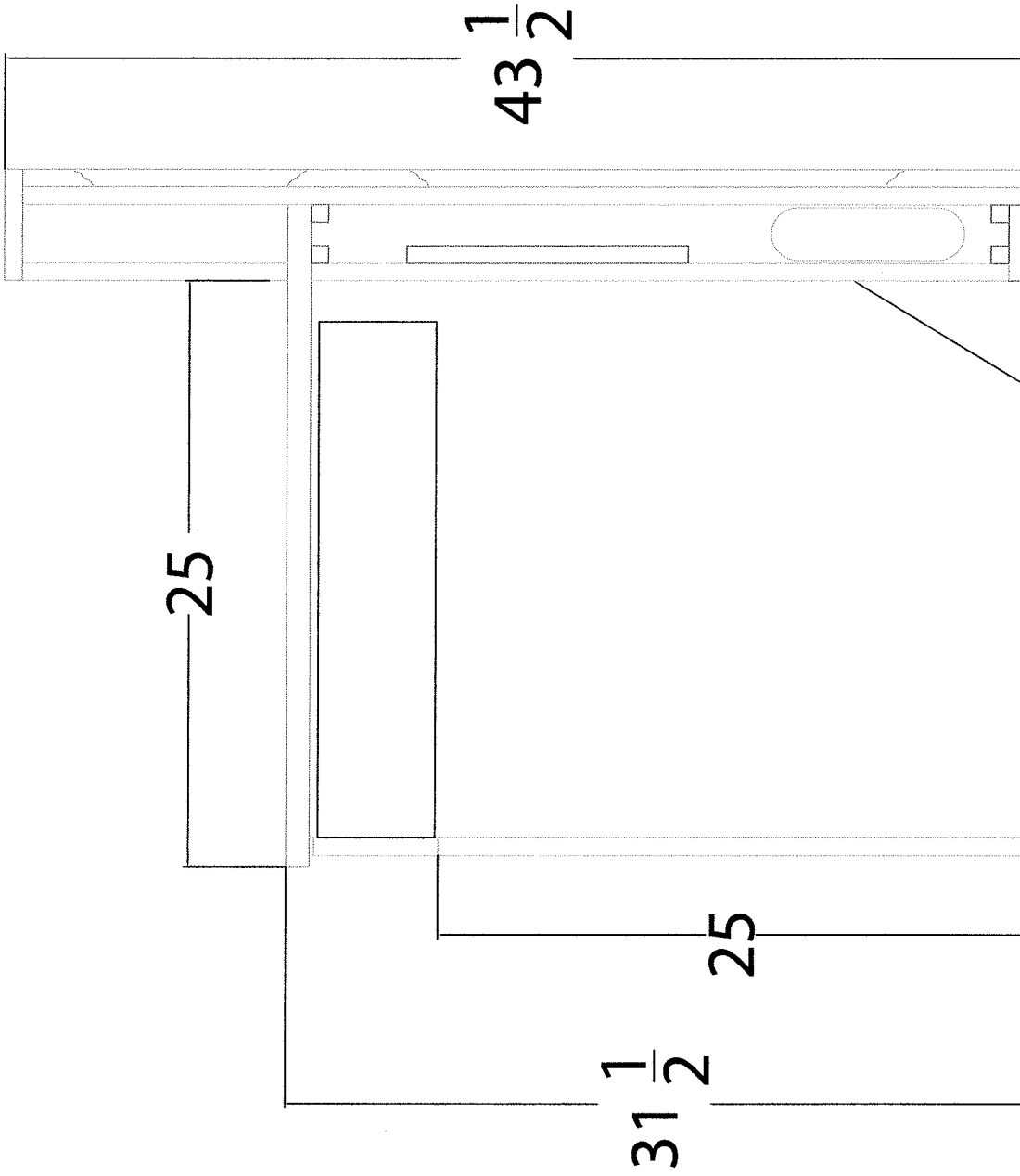

REMOVABLE PANEL FOR  
WIRE MANAGEMENT

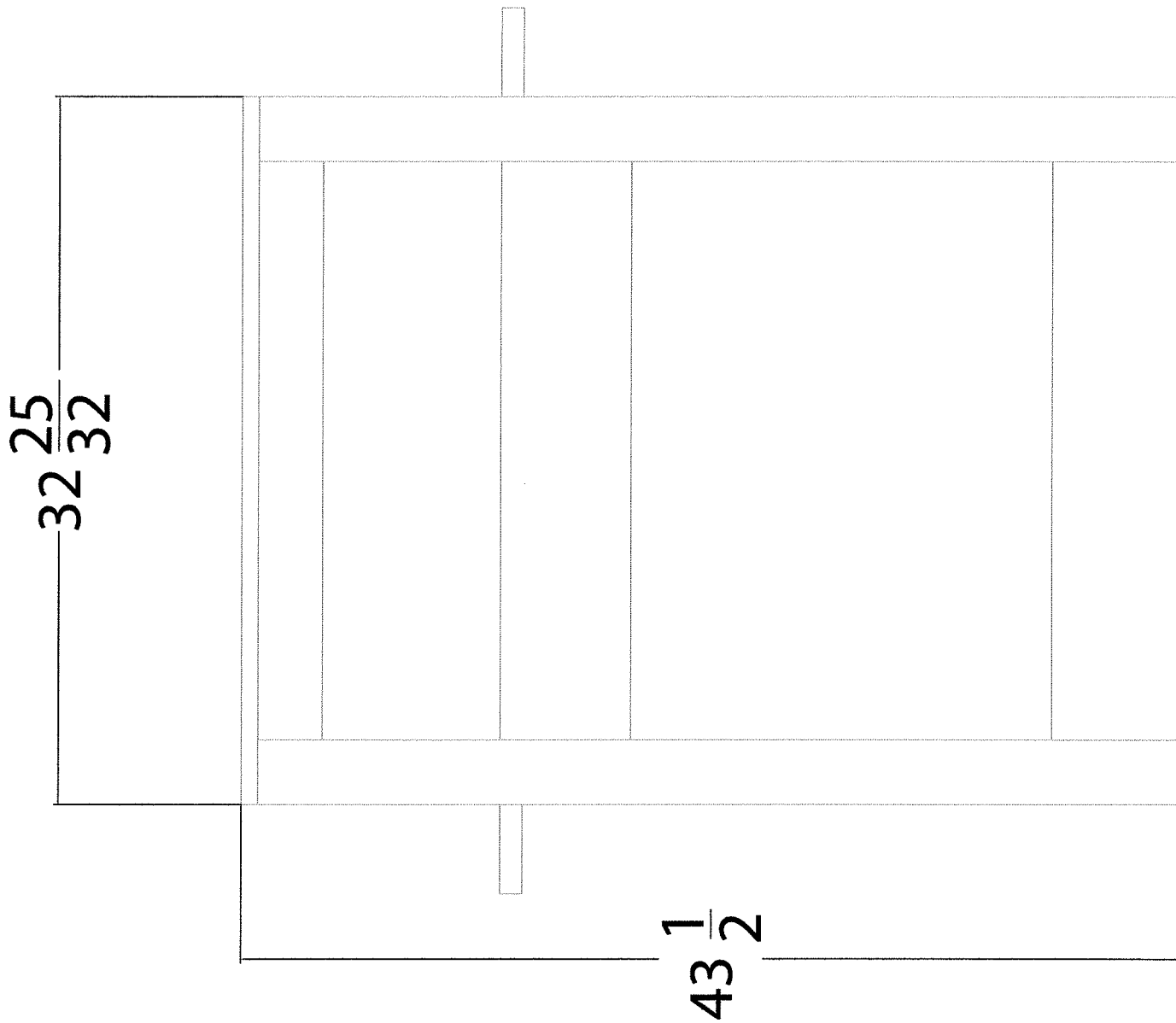



LEISURE CRAFT, INC.  
 P.O. Box 1700  
 Hendersonville, NC 28793  
 Phone: 828-693-8241  
 Fax: 828-693-8777

*OPTION 3*  
**QUOTE**

Date	Estimate #
7/24/2008	14631

Name / Address
HENDERSON COUNTY 213 1ST AVE EAST HENDERSONVILLE NC 28792

Ship To
HENDERSON COUNTY 213 1ST AVE EAST HENDERSONVILLE, NC 28792 Bill Moyer

LCI Rep	Terms	Rep	FOB	Phone/Fax
	Net 30	JT	Hendersonv'le	

Qty	Item	Description	Rate	LCI Rep	Total
8	MISC	DESK UNITS FOR COMMISSIONERS BOARD ROOM	1,183.00		9,464.00
2	MISC	DECORATIVE ENDS FOR DESK ASSEMBLY	187.50		375.00
1	MISC	INSTALLATION	975.00		975.00
1	MISC	SALES TAX	729.95		729.95
<p>QUOTATION TO BE FINALIZED UPON APPROVAL OF FINISH AND LAMINATE SAMPLES            QUOTATION DOES NOT INCLUDE REMOVAL OF EXISTING FURNITURE AND THE ROUTING OF CABLES</p> <p>Jim Tomes</p>					
			<b>Total</b>		\$11,543.95