

## **REQUEST FOR COMMITTEE ACTION**

### **HENDERSON COUNTY TECHINICAL REVIEW COMMITTEE**

**MEETING DATE:** Tuesday, May 17, 2016

**SUBJECT:** Combined Master and Development for Butler Bridge Cottages,  
Major Subdivision (2016-M04)

**STAFF CONTACT:** Kyle Guie, Planner

**ATTACHMENTS:**

1. Staff Report
2. Vicinity Map
3. Subdivision Application with Attachments
4. Combined Master & Development Plan

#### **SUMMARY OF REQUEST:**

Will Buie on behalf of Windsor Built Homes, submitted a Combined Master and Development Plan for Butler Bridge Cottages major residential subdivision. The project site is located on 2.919 acres of land (PIN 9652-01-0661) located off Butler Bridge Road (SR 1345). The applicant is proposing a total of 12 lots that will be used for single-family residential purposes. The project is not located within a water supply watershed district nor is it located within the floodplain (see Attachment 4, Combined Master and Development Plan). The project is located in the Residential One (R1) zoning district and does meet the intermediate density requirements. A private road is proposed to serve the project site. City of Asheville water line and Cane Creek sewer lines are proposed to serve the site.

#### **TECHNICAL REVIEW COMMITTEE ACTION REQUESTED:**

Staff has found that the Combined Master and Development Plan appear to meet the standards of the subdivision regulations of Chapter 42A, Henderson County Land Development Code (LDC) except for the comments listed in the Staff Report (See Attachment 1).

Staff recommends approval of the Combined Master and Development Plan subject to the developer addressing any issues raised by the TRC and addressing the comments listed in the Staff Report.

**Suggested Motion:** I move that the TRC recommend approval the Combined Master and Development plan with the conditions noted in the staff report and any others noted by the TRC.

---

**Henderson County Planning Department Staff Report****Combined Master and Development Plan  
Butler Bridge Cottages (2016-M04)****Property Owner(s): William and Nancy Johnson  
Applicant: Windsor Built Homes**

---

**Master Plan Comments:**

According to Chapter 42A, Henderson County Land Development Code (LDC) §42A-341, the purpose of a Master Plan is to provide general information about the proposed development to allow for an assessment of its impact on the orderly growth and development of the County, environmental quality, land values, natural features identified on the site analysis sketch and the County's roads and governmental services. During the review of the Master Plan, the Technical Review Committee should take into consideration: applicable recommendations of the *Henderson County 2020 Comprehensive Plan*, the potential use of the land to be subdivided, and the impact of the subdivision and proposed use whether residential, commercial or industrial.

When reviewing the Master Plan it is important to consider that, due to severe topographic conditions, inadequate road access, distance from services, unique natural areas, soils that do not easily support soil drainage systems and/or the proximity to existing and incompatible land uses/zoning, all land may not be suitable to be subdivided for the purpose of dense development (LDC §42A-75).

Staff has reviewed the submitted Master Plan for the Butler Bridge Cottages Major Subdivision, taking into consideration the recommendations of the *Henderson County 2020 Comprehensive Plan* and reviewing the plan for conformance with Henderson County Land Development Code. Staff offers the following comments:

1. ***Henderson County 2020 Comprehensive Plan (CCP)***. The Future Land Use Map of the CCP shows the Subject Area as being located within the Urban Services Area (See Map A: CCP Future Land Use Map).
  - a. The Urban Services Area is that area within which most urban services and urban- scale development is currently concentrated, and within which such development should generally be concentrated through the year 2020. Growth and development will be proactively managed through extensive planning. Much of the USA falls within municipal planning jurisdictions and will be managed by those jurisdictions. Land use planning for areas falling within the County's jurisdiction should be comparable and compatible in its approach and intensity with planning conducted within the various municipal jurisdictions.

**Map A: County Comprehensive Plan Future Land Use Map**

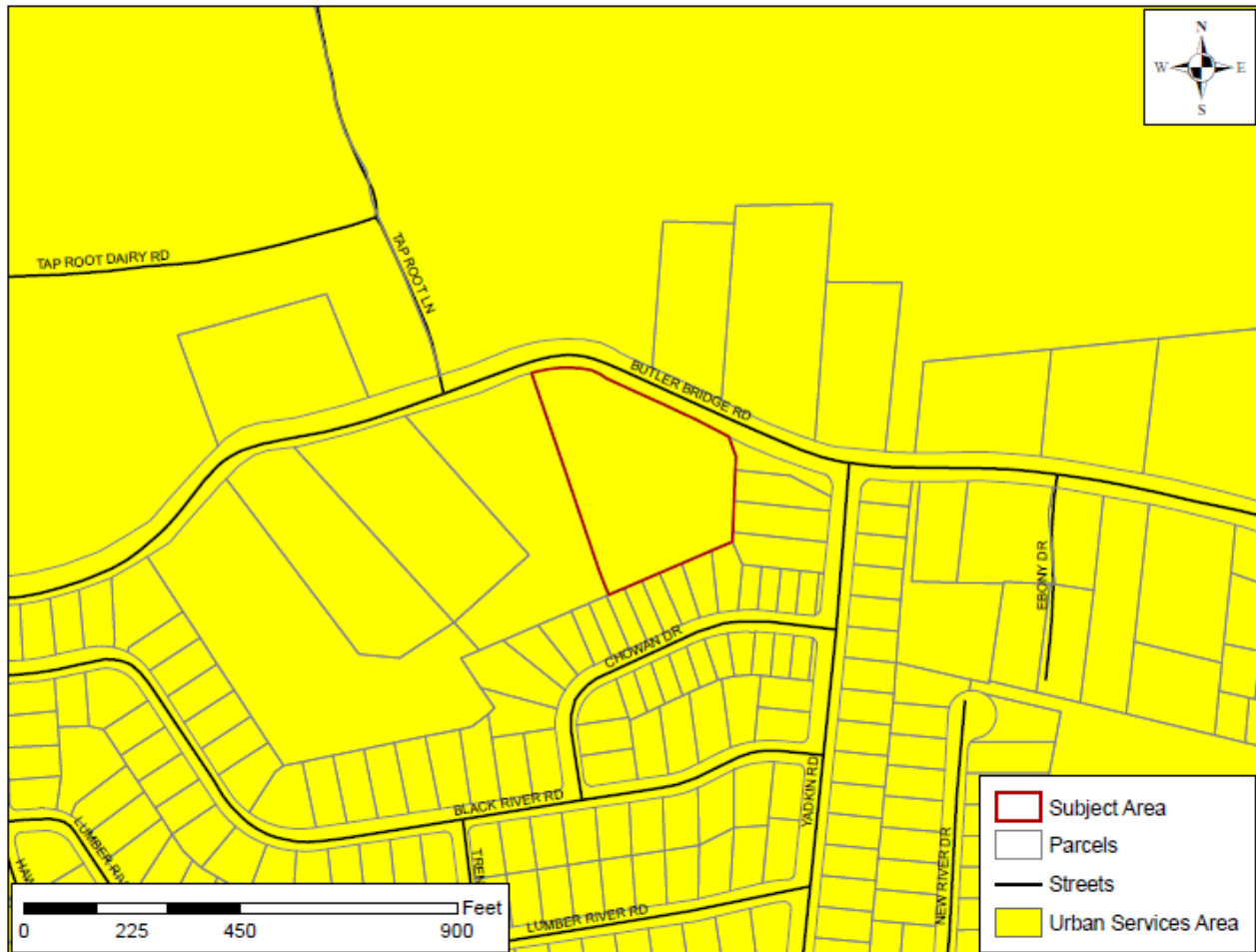

According to the plan, the project would have an average density of approximately 4.11 units per acre.

2. **Chapter 42A, Henderson County Land Development Code (LDC).** According to Chapter 42A, Henderson County Land Development Code (LDC) and its Official Zoning Map adopted September 19, 2007 (as amended), the proposed project site is located within the Residential One (R1) (See Map B: Official Zoning Map). The current R1 zoning district allows for single-family and multifamily units.

R1 allows for a standard residential density of 4 units per acre and an intermediate density of 8 units per acres. The intermediate density requires public water and public sewer connections. Therefore, the LDC allows for 23 units of the project site at an intermediate density. The Master and Development Plan proposal of 12 lots would fall within the density permitted by the LDC.

### Map B: Official Zoning Map

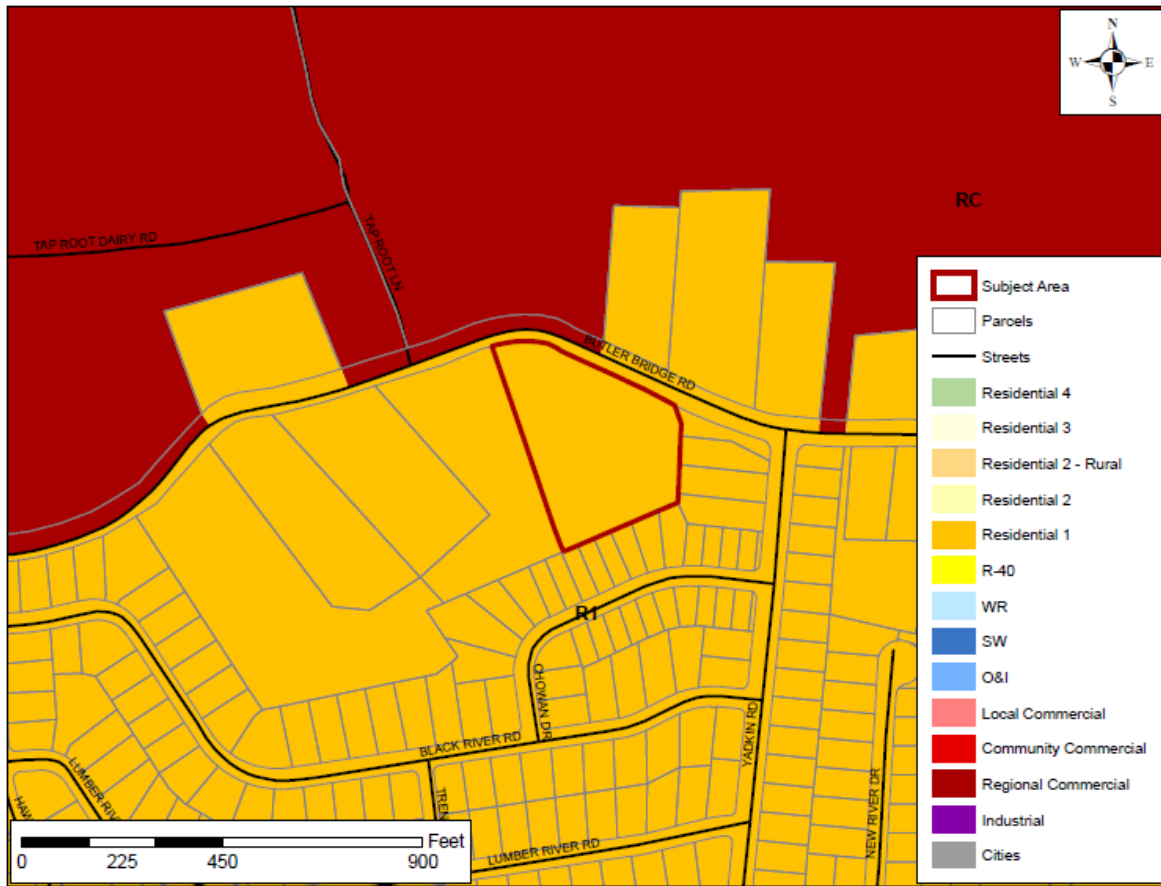

- 3. Water and Sewer Availability.** The applicant proposes connections to the City of Asheville water line and Cane Creek sewer already serving adjacent properties in the Riverstone Major Subdivision. (Map C: Utilities Map).

**Map C: Public Utilities**

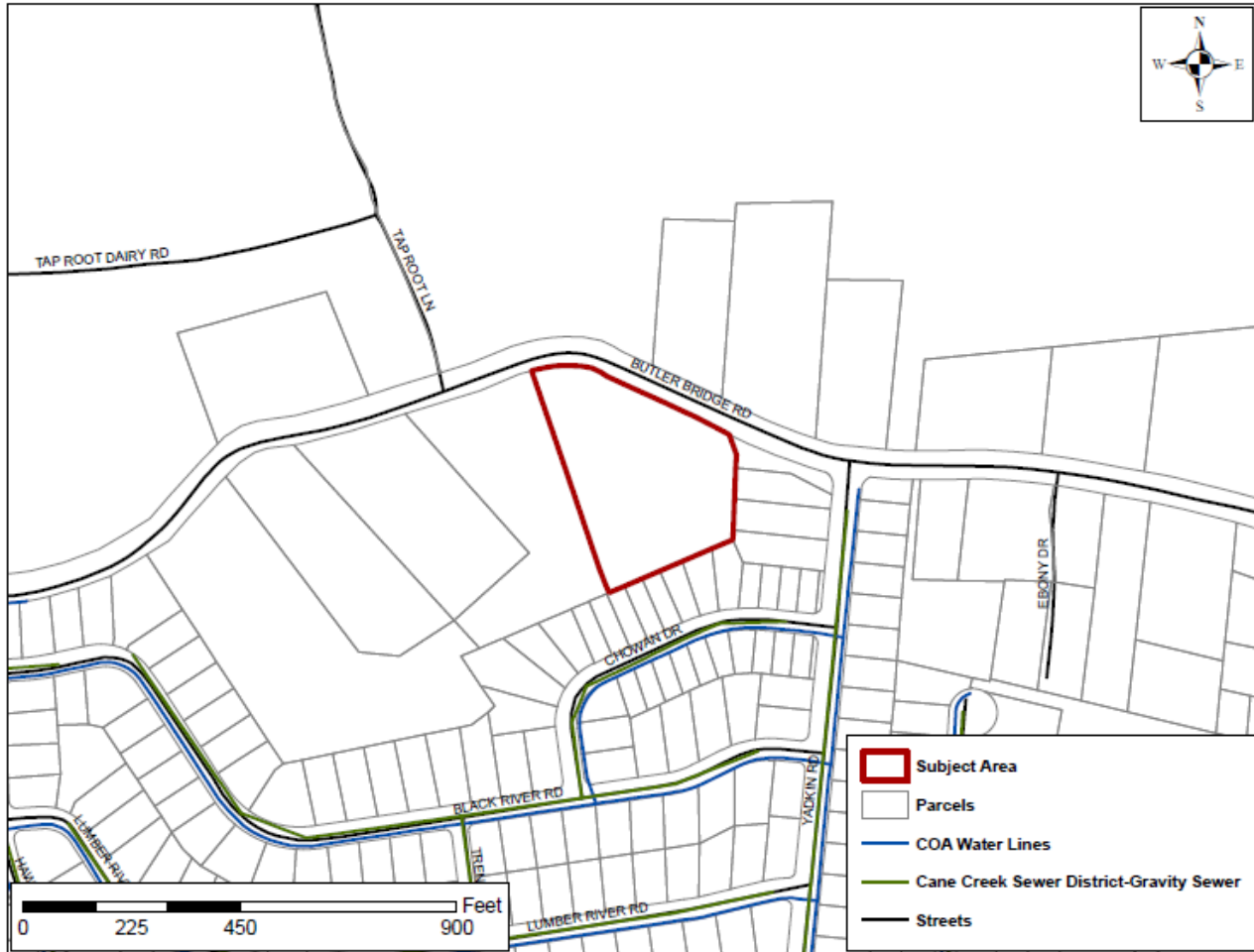

**Master Plan Comments:**

- 1. Soil Erosion and Sedimentation Control Plan.** The Applicant shall submit written notice from the appropriate local agencies verifying that an Erosion and Sedimentation Control Plan has been received or a written notice from a professional land surveyor, engineer, landscape architect, architect, or professional planner certifying that no plan is required (LDC §42A-113B).
- 2. Private Roads.** The final plat(s) must contain a note stating: *The private roads indicated on this final plat may not meet the requirements of the North Carolina Department of Transportation for acceptance into the state road system.*
- 3. Shoulder Stabilization.** All areas disturbed by the construction of a private road, including cut and fill slopes, shoulders and ditch banks, shall be seeded to stabilize the soil and prevent erosion. Seeding should be done as soon as feasible after road construction (LDC §42A-97).

4. **Road Drainage, Culverts and Shoulder Stabilization.** Road or drainage structures shall be constructed in accordance with state roads standards. Road drainage side ditches shall be constructed with sufficient depth and width to carry the expected volume of storm water runoff (LDC §42A-100). All areas disturbed by the construction of a private road, including cut and fill slopes, shoulders and ditch banks, shall be seeded to stabilize the soil and prevent erosion. Seeding should be done as soon as feasible after road construction (LDC §42A-97).
5. **Road Name Approval.** Proposed road names for a private and/or public road shall be preapproved by Henderson County in accordance with Chapter 42 of the Henderson County Code, Property Addressing (LDC §42A-98). The applicant lists the proposed road names for most road segments. The names of the shared drives should be confirmed with the development plan approval.
6. **Street Tree Requirements.** According to the street tree requirements of Chapter 42A (LDC §42A-145 and LDC §42A-146) the applicant must provide one tree per 50 linear feet of property abutting an internal road. Trees may be placed in groups with a minimum spacing of no less than 15 feet and a maximum spacing of no more than 65 feet. The trees may be placed within the right-of-way or within 20 feet of the edge of the right-of-way. The applicant may use existing trees in accordance with LDC §42A-153 instead of planting new trees. These existing trees must also be located within the right-of-way or 20 feet off the edge of the right-of-way as required by LDC §42A-146
7. **Pedestrian Access.** Sidewalks or walking trails are required for any major subdivision of 10 or more lots outlined in Henderson County Code Chapter 42A (LDC §42A-113). Reasonable pedestrian access shall be provided to promote healthy and safe walking when a developer proposes a density equal to or greater than two (2) units per acre. The applicant must provide one (1) linear foot of sidewalk or walking trail for every linear foot of improved or newly proposed roadway within the tract. Sidewalks or walking trails are to be located in a road right-of-way, pedestrian access to easement, or other dedicated open space. Sidewalks are to be constructed at a minimum of 5 feet in width using concrete, asphalt, or other permanent all-weather surface such as gravel.
8. **Floodplain.** A Floodplain Permit is required for any proposed development parcel that contains Floodplain.
9. **Gates.** Entry gates shall be constructed and maintained as required by and in accordance with Chapter 89 of the Henderson County Code, Entry Gates, and SR 3.7 (Gates and/or Guardhouses). LDC §42A-105 C
10. **Miscellaneous Advisory Provisions.** The Applicant should become familiar with the Miscellaneous Advisory Provisions of Chapter 42A (LDC §42A-87).
11. **Final Plat Requirements.** The Final Plat(s) must meet the requirements provided by the Planning Department whenever a subdivision of land occurs (LDC §42A-343).



Butler Bridge Cottages Major Subdivision  
Applicant: Windsor Built Homes  
(#2016-M04)

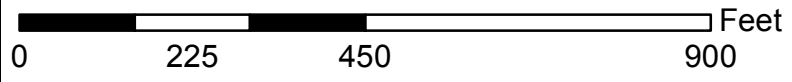

-  Subject Area
-  Parcels
-  Streets





# WGLA Engineering, PLLC

Civil Engineering & Land Planning

May 3, 2016

Mr. Kyle Guie  
Henderson County Planning Department  
100 N. King Street  
Hendersonville, NC 28792

RE: Butler Bridge Cottages  
Combined Master Plan/Development Plan  
WGLA #16132

Dear Mr. Guie:

Please find enclosed four copies of the combined master plan/development plan for the Butler Bridge Cottages located of Butler Bridge Road adjacent to the Riverstone subdivision. This project involves the development of 12 single family lots on approximately 3 acres. Public water (City of Asheville system) and public sewer (Cane Creek Sewer District) will be extended to the property from the Riverstone subdivision.

In addition to the plans referenced above, please find enclosed the completed check list, appointment of agent, and application form for the subdivision. Additionally, I have attached the requests for water availability and wastewater allocation.

If you have any questions or need additional information, don't hesitate to contact our office.

Sincerely,  
WGLA Engineering, PLLC

William R. Buie, P.E.



APPOINTMENT OF AGENT FORM (OPTIONAL)

I William F. and Nancy Moore Johnston owner of property located on Butler Bridge Road,  
(Name) (Street Name)

recorded in 769/483 and having a parcel identification number of 9652-01-0681,  
(Deed Book/Page) (PIN)

located in Henderson County, North Carolina, do hereby appoint Drew Norwood, Windsor Built Homes,  
(Agent's Name)

to represent me in an **application to the Planning Department** and authorize him/her to act as my agent **in all matters**, formal and informal except as stated herein, and authorize him/her to receive all official correspondence.

I however understand that as the listed property owner, I must sign all affidavits and statements required by any applicable ordinance.

William F. Johnston  
Property Owner

5-2-16  
Date

**HENDERSON COUNTY  
SUBDIVISION APPLICATION FORM**  
(Please fill out all applicable items)

**SUBDIVISION INFORMATION**

Subdivision Name: Butler Bridge Cottages

Subdivision Type (Circle One): Major      Minor      Non-Standard      Special

Proposed Use of Property (Circle One): Residential      Commercial      Industrial

Conservation Subdivision:      Yes      No      Gated entrance to property:      Yes      No

Existing Number of Lots: 1      Total Number of Proposed Lots: 13

Total Number Proposed Units: 12      Proposed Density (units per acre): 4.11 units/Acre

Road System:    ( ) Public      (X) Private      ( ) Combination Public and Private

Water System: ( ) Individual      ( ) Community      (X) Municipal

Sewer System: ( ) Individual      ( ) Community      (X) Municipal

**PARCEL INFORMATION**

PIN: 9652-01-0661      Total Acreage: 2.919 AC      Deed Book/Page: 769/483      Township Hoopers Creek

Location of property to be divided: Butler Bridge Road adjacent to Riverstone Subdivision

Zoning District: R-1      Fire District: Fletcher

Water Supply Watershed: N/A      School District: West Henderson

Any portion of property within or containing the following:

Floodplain or floodway:      Yes      No      Perennial streams:      Yes      No

Protected mountain ridges:      Yes      No      Cemetery:      Yes      No

Within 1/2 mile of a Farmland Preservation District:      Yes      No

Adjacent to a Farmland Preservation District:      Yes      No

**CONTACT INFORMATION**

**Property Owner:**  
Name: William and Nancy Johnston      Phone: \_\_\_\_\_  
Address: 1492 Jeffress Road      City, State, Zip: Mills River, NC 28759

**Applicant:**  
Name: Windsor Built Homes      Phone: 864-271-9855  
Address: 40 West Broad Street, Suite 500      City, State, Zip: Greenville, SC 29601

**Agent:** Agent Form (Circle One):      Yes      No  
Name: \_\_\_\_\_      Phone: \_\_\_\_\_  
Address: \_\_\_\_\_      City, State, Zip: \_\_\_\_\_

**Plan Preparer:**  
Name: Will Buie, WGLA Engineering      Phone: 828-687-7177 ext 302  
Address: 214 N. King Street      City, State, Zip: Hendersonville, NC 28792

I certify that the information shown above is true and accurate and is in conformance with the Subdivision regulations of Henderson County.

F.A. Norwood      [Signature]      4/27/16  
Print Applicant (Owner or Agent)      Signature Applicant (Owner or Agent)      Date

**County Use Only**

Fee: \$ \_\_\_\_\_ Paid: \_\_\_\_\_ Method: \_\_\_\_\_ Final Plat Approved On: \_\_\_\_\_

## DEVELOPMENT PLAN REQUIREMENTS

A Professional Engineer, Land Surveyor, Architect, Landscape Architect, or Professional Planner may prepare the Development Plan. The following information shall be shown on the plan for information and discussion purposes unless not applicable or specifically waived by the Subdivision Administrator\*. **If the Development Plan does not contain the required items by the submittal deadline, the application will be considered incomplete and the plan will not be presented to the Planning Board.** Combined Master and Development Plans must also be prepared in accordance with Master Plan Requirements provided by the Planning Department. More information about Development Plans can be found in Section 200A-310 in the Land Development Code. For each item below, please indicate whether the requested information has been provided.

### General Legend

Yes	No	
<input checked="" type="checkbox"/>	<input type="checkbox"/>	Scale (written and graphic): Scale for full-sized and reduced copies should be appropriate to clearly depict property
<input checked="" type="checkbox"/>	<input type="checkbox"/>	North arrow
<input checked="" type="checkbox"/>	<input type="checkbox"/>	Owner's and applicant's names and addresses
<input checked="" type="checkbox"/>	<input type="checkbox"/>	Legend provide appropriate symbols
<input checked="" type="checkbox"/>	<input type="checkbox"/>	Vicinity map
<input type="checkbox"/>	<input type="checkbox"/>	Phase map showing location of phase in the entire development (if applicable)

If no was checked for any above, please explain: \_\_\_\_\_

---

### Title Block

Yes	No	
<input checked="" type="checkbox"/>	<input type="checkbox"/>	Project name (include phase number, if applicable)
<input checked="" type="checkbox"/>	<input type="checkbox"/>	Title of map (must state "Development Plan" or "Combined Master & Development Plan," as applicable)
<input type="checkbox"/>	<input type="checkbox"/>	When using the conservation subdivision option must also be labeled as "Conservation Subdivision"
<input checked="" type="checkbox"/>	<input type="checkbox"/>	Name, address, and phone number of individual or firm preparing the various elements of the plan
<input checked="" type="checkbox"/>	<input type="checkbox"/>	Date and revision date(s), if required

If no was checked for any above, please explain: \_\_\_\_\_

---

### Project Summary

Yes	No	
		<b>Project summary containing the following information:</b>
<input checked="" type="checkbox"/>	<input type="checkbox"/>	Total project (or phase) area in acres
<input type="checkbox"/>	<input type="checkbox"/>	Number of proposed lots/units by type
<input checked="" type="checkbox"/>	<input type="checkbox"/>	Proposed density (units/acres)
<input checked="" type="checkbox"/>	<input type="checkbox"/>	Total acreage of land that have slopes of 60 percent or greater
<input checked="" type="checkbox"/>	<input type="checkbox"/>	Minimum lot size in square feet (excluding road right-of-way if in the R-40 and WR zoning districts)
<input type="checkbox"/>	<input type="checkbox"/>	Length of proposed public roads (must meet NCDOT minimum road standards)



- X    \_\_\_    Length of proposed private roads (must meet Henderson County minimum roads standards Section 280A-81 C)
- X    \_\_\_    Water system \_\_\_\_\_ (public/private/individual)
- X    \_\_\_    Sewer system \_\_\_\_\_ (public/private/individual)
- X    \_\_\_    Distance to public water system
- X    \_\_\_    Distance to public sewer system

If no was checked for any above, please explain: \_\_\_\_\_  
\_\_\_\_\_

**Plan Details**

- | <u>Yes</u> | <u>No</u> |   |
|------------|-----------|---|
| <u>X</u>   | ___       | Contours at no more than five foot (5') intervals   |
| <u>N/A</u> | ___       | Location of existing ponds, lakes or watercourses and directions of flow  |
| <u>X</u>   | ___       | Outside boundaries of the proposed project with bearings and distances  |
| <u>N/A</u> | ___       | Approximate location of the 100-year flood hazard line, if applicable   |
| <u>X</u>   | ___       | Location of existing roads with rights-of-way, easements, bridges, water features, culverts, utilities, structures, etc.  |
| <u>N/A</u> | ___       | Location of proposed ponds and lakes shown with approximate elevation, and proposed alterations to existing water courses, if applicable                                      |
| <u>X</u>   | ___       | Names of adjoining property owners or subdivisions  |
| <u>N/A</u> | ___       | Proposed locations of multi-family units shown, if applicable   |
| <u>X</u>   | ___       | Proposed lot lines and approximate length   |
| <u>X</u>   | ___       | Proposed lot numbers shown  |
| <u>X</u>   | ___       | Size of lots to 0.1 acres (not including road right-of-way for property zoned R-40 and WR)  |
| <u>X</u>   | ___       | Proposed open space or common area clearly shown and labeled  |
| <u>X</u>   | ___       | Proposed water system (public/private) improvements including approximate location of proposed waterlines   |
| <u>X</u>   | ___       | Proposed sewer system (public/private) improvements including approximate location of proposed sewerlines, pump stations, wastewater treatment plants, etc.                   |
| <u>X</u>   | ___       | Fire hydrants spaced one hydrant per 1,000 feet of linear road, if applicable   |
| <u>N/A</u> | ___       | Location of nearest water supply point for fire protection and location of proposed dry hydrants as described in Section 200A-81 B(3), if not served by a public water system |
| <u>X</u>   | ___       | Location of proposed project sign(s) and easement for sign, if applicable   |
| <u>N/A</u> | ___       | Water supply watershed boundaries, zoning district lines, fire district lines and municipal, county, or state boundaries, if applicable                                       |
| <u>X</u>   | ___       | Location and approximate layout of recreation areas, club houses, mail delivery points or other project features  |
| <u>X</u>   | ___       | Proposed buffers (location and type), if applicable   |
| <u>X</u>   | ___       | Proposed drainage improvements (designed according to NCDOT standards) including  |
|            | <u>X</u>  | Culvert locations   |
|            | <u>X</u>  | Length  |
|            | <u>X</u>  | Diameter (minimum 18 inches)  |
|            | <u>X</u>  | Type  |
|            | <u>X</u>  | Drainage easements  |
| <u>N/A</u> | ___       | Location of lots or parcels reserved for future development, utility stations, public parks, schools, churches and etc., if applicable  |

<u>X</u>	<u>    </u>	Current zoning and proposed or required building setbacks shown or labeled
<u>N/A</u>	<u>    </u>	100-foot farmland preservation district setback, if applicable (see Section 200A-81 O)
<u>N/A</u>	<u>    </u>	Setback from perennial stream(s), if applicable (see Section 200A-81 S)
<u>X</u>	<u>    </u>	Location, design and materials of all proposed sidewalks and/or walking trails as described in Section 200A-81 Q, if applicable
<u>X</u>	<u>    </u>	Arrangement of plant material and description of plant material clearly indicated on plan in accordance with Article V (Landscape Design Standards) Subpart C (Street Tree Requirements) of the Land Development Code
<u>N/A</u>	<u>    </u>	All land with a slope of 60 percent or greater clearly shown on plan, if applicable

**Road Details**

<b>Yes</b>	<b>No</b>	
<u>X</u>	<u>    </u>	Location of proposed streets/roads showing:
	<u>X</u>	Rights-of-way
	<u>X</u>	Approximate finished road grades
	<u>X</u>	Approximate centerline curve radii (see Section 200A-81 C)
<u>X</u>	<u>    </u>	Cross-section of typical street for each proposed road classification used (collector, local, etc.) with indication of design standards of paving/base to be met, road width, right-of-way width, shoulder width, cut and fill slope, and ditch slope
<u>X</u>	<u>    </u>	Cross-section or plan view of cul-de-sac and/or alternate turnarounds with indication of design standards of paving/base to be met, road width, right-of-way width, shoulder width, cut and fill slope, and ditch slope
<u>N/A</u>	<u>    </u>	All roads or sections thereof with dead-ends or culs-de-sac no more than 2,500 feet in length
<u>N/A</u>	<u>    </u>	Location and design of proposed entry gates
<u>X</u>	<u>    </u>	Intersections at 60 degree angles or greater
<u>X</u>	<u>    </u>	Site triangles conforming to Section 200A-81C
<u>N/A</u>	<u>    </u>	Bridges and easements
<u>X (to follow)</u>	<u>    </u>	Proposed road(s) named and received name(s) approval from Henderson County Property Addressing and are designated as public/private

**Conservation Subdivision (Option)**

<b>Yes</b>	<b>No</b>	
<u>    </u>	<u>    </u>	Percentage of total acreage in open space
<u>    </u>	<u>    </u>	Primary conservation areas clearly identified
<u>    </u>	<u>    </u>	Secondary conservation areas clearly identified
<u>    </u>	<u>    </u>	Uses of open space clearly indicated on plan
<u>    </u>	<u>    </u>	Bona fide agricultural operations on site
<u>    </u>	<u>    </u>	Driveway easements clearly shown with right-of-way width and driveway length
<u>    </u>	<u>    </u>	Setbacks and separation of all structures labeled or shown
<u>    </u>	<u>    </u>	50 percent of proposed open space in a contiguous tract
<u>    </u>	<u>    </u>	Management Open Space Plan submitted with Development Plan



**Other Development Plan Application Requirements**

The following information and/or other items shall be provided or otherwise addressed in writing by the submittal deadline of the application for Development Plan approval unless not applicable or specifically waived by the Subdivision Administrator\*, otherwise the application will be considered incomplete and will not be presented to the Planning Board.

Yes	No	
<input checked="" type="checkbox"/>	<input type="checkbox"/>	Application Form: Filled-out and signed by property owner
<input checked="" type="checkbox"/>	<input type="checkbox"/>	Agent Form: Filled-out and signed by property owner, if applicable
<input checked="" type="checkbox"/>	<input type="checkbox"/>	Fee
<input checked="" type="checkbox"/>	<input type="checkbox"/>	Development Plan (or Combined Master and Development Plan [4 full-sized copies & 1 reduced copy per Section 200A-310]). Please submit digital copies to the planning staff.
<input checked="" type="checkbox"/> (to follow)	<input type="checkbox"/>	Where connection to a public or community water and/or sewer system is required or otherwise proposed, the applicant shall submit a letter from the appropriate review authorities for the water and/or sewer system indicating that water and/or sewer system has sufficient capacity for the proposed development.
<input type="checkbox"/> N/A	<input type="checkbox"/>	Traffic Impact Study (TIS) (Section 200-81 S(5)), if applicable
<input type="checkbox"/> N/A	<input type="checkbox"/>	Emergency Services Impact Report (ESIR) (Section 200-81 S(5)), if applicable
<input type="checkbox"/>	<input type="checkbox"/>	List any additional attachment(s) below: (if applicable) _____

If no was checked for any above, please explain: \_\_\_\_\_

The following information shall be provided or otherwise addressed in writing by submittal deadline of the application for Development Plan approval; however, the Planning Board may conditionally approve the Development Plan subject to receipt of such information if it is not available at the time of the Planning Board review:

Yes	No	
<input type="checkbox"/>	<input type="checkbox"/>	Additional information as required to adequately explain the character or services of the proposed development
<input type="checkbox"/>	<input type="checkbox"/>	Approval of intermediate water and sewer systems to be used, if applicable
<input type="checkbox"/>	<input type="checkbox"/>	Final Approval of plans for proposed water and sewer systems
<input type="checkbox"/>	<input type="checkbox"/>	Erosion and sedimentation control plan approval from Henderson County Erosion Control Division, evidence of submission from the Henderson County Erosion Control Division, or certification that no plan is required in accordance with Section 200A-224
<input type="checkbox"/>	<input type="checkbox"/>	Any other approvals as required by Federal, State, or Local agencies
<input type="checkbox"/>	<input type="checkbox"/>	Bridge design plans in accordance with Section 200A-81 D, if applicable
<input type="checkbox"/>	<input type="checkbox"/>	Affidavit of Understanding of Farmland Preservation District (if applicable)

If no was checked for any above, please explain: \_\_\_\_\_



*\* Any waived item(s) must be documented on a waiver form provided by Staff*

Application completed and submitted by: W. O. R. Date: 5.2.16

.....  
COUNTY USE ONLY  
.....

Received by: MAH Champion Date: 5/3/16

Comments: \_\_\_\_\_  
\_\_\_\_\_  
\_\_\_\_\_  
\_\_\_\_\_



**WGLA Engineering, PLLC**  
CONSULTING ENGINEERS & LAND PLANNERS  
HENDERSONVILLE, NORTH CAROLINA

**BUTLER BRIDGE COTTAGE**  
HENDERSON COUNTY  
NORTH CAROLINA

**COMBINED MASTER PLAN/  
DEVELOPMENT PLAN**

sheet  
C-200

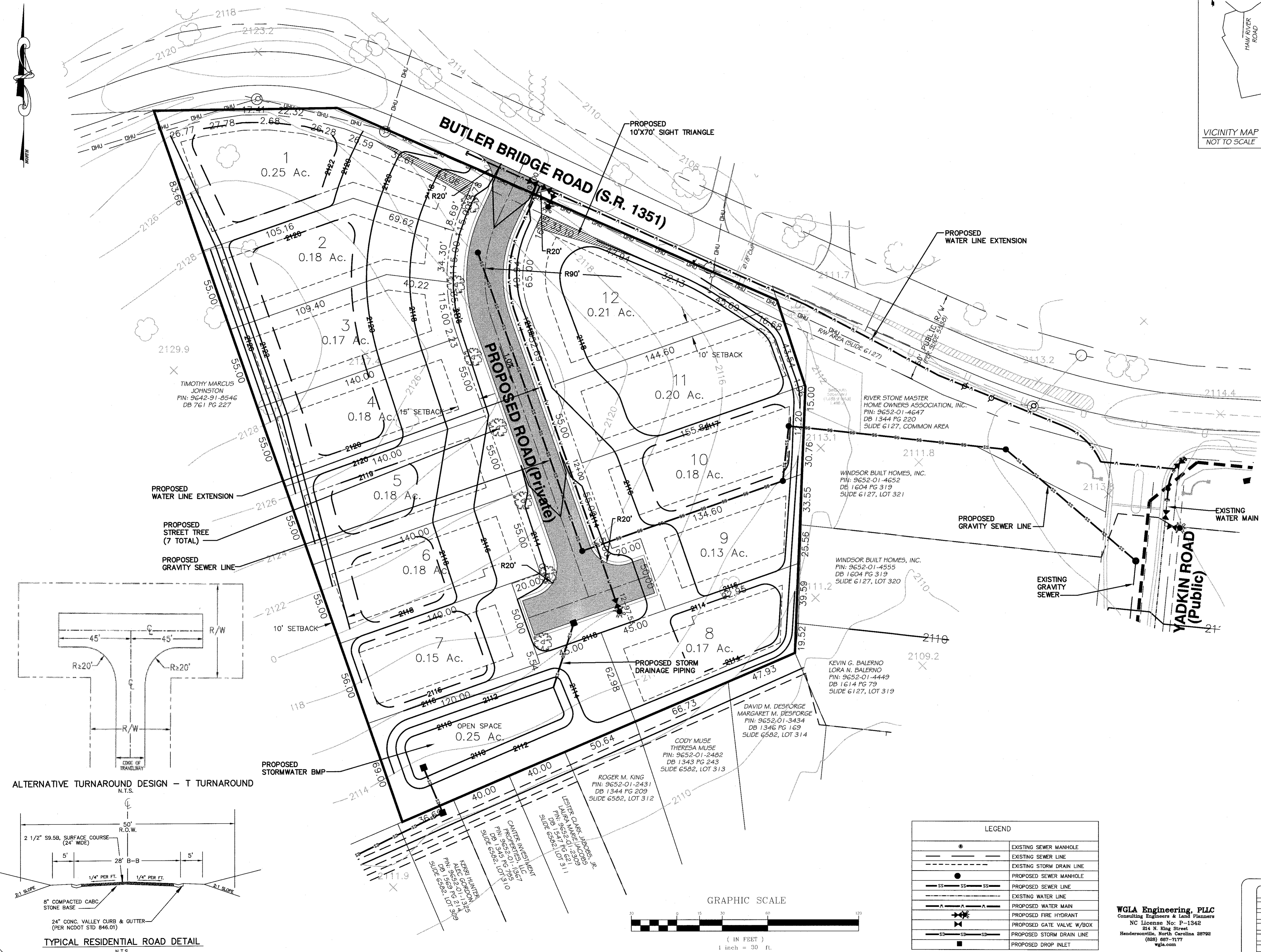
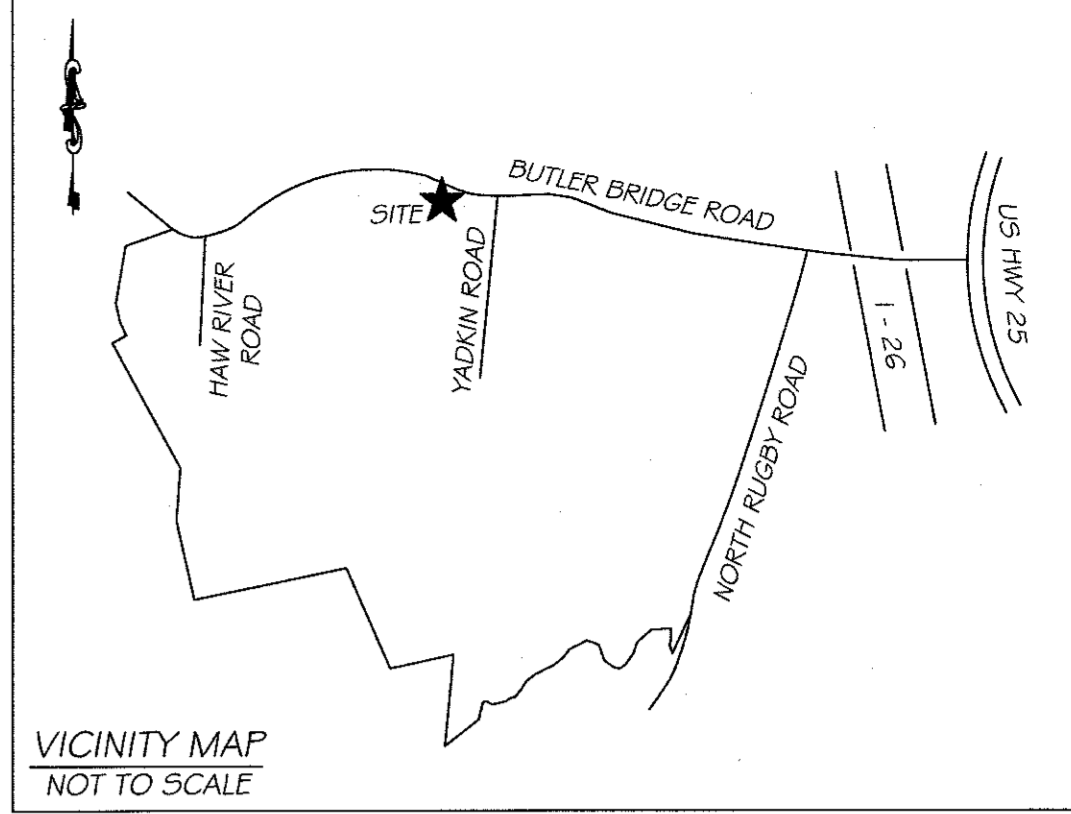

**PROJECT SUMMARY**

PROPERTY OWNER:  
WILLIAM F & NANCY MOORE JOHNSTON  
1492 JEFFRESS RD  
MILLS RIVER, NC 28759

PIN# 9652-01-0661  
DB 769 PG. 483

DEVELOPER:  
WINDSOR BUILT HOMES  
40 WEST BROAD STREET  
SUITE 500  
GREENVILLE, SC 29601  
800-487-5214

ZONING: R1 (HC)  
TOTAL ACRES: 2.919 AC  
TOTAL LOTS: 12  
MINIMUM LOT SIZE: 0.13 AC  
MAXIMUM LOT SIZE: 0.25 AC  
PROPERTY DENSITY: 4.11 UNITS/ACRES  
LENGTH OF ROADS: 306 LF (PRIVATE)  
FIRE DISTRICT: FLETCHER  
PUBLIC WATER: CITY OF ASHEVILLE  
PUBLIC SEWER: CANE CREEK DISTRICT

BLDG SETBACKS:  
FRONT 15'  
SIDE 10'  
REAR 10'

NOTES:  
SURVEY INFORMATION PROVIDED BY MCABEE & ASSOCIATES  
LOTS WILL BE SINGLE FAMILY HOMES ONLY

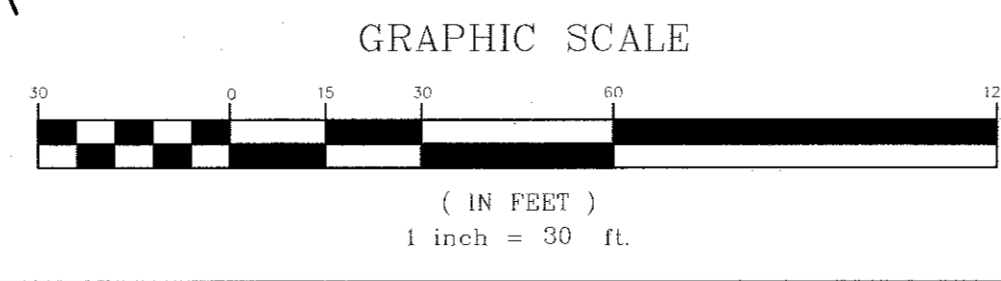
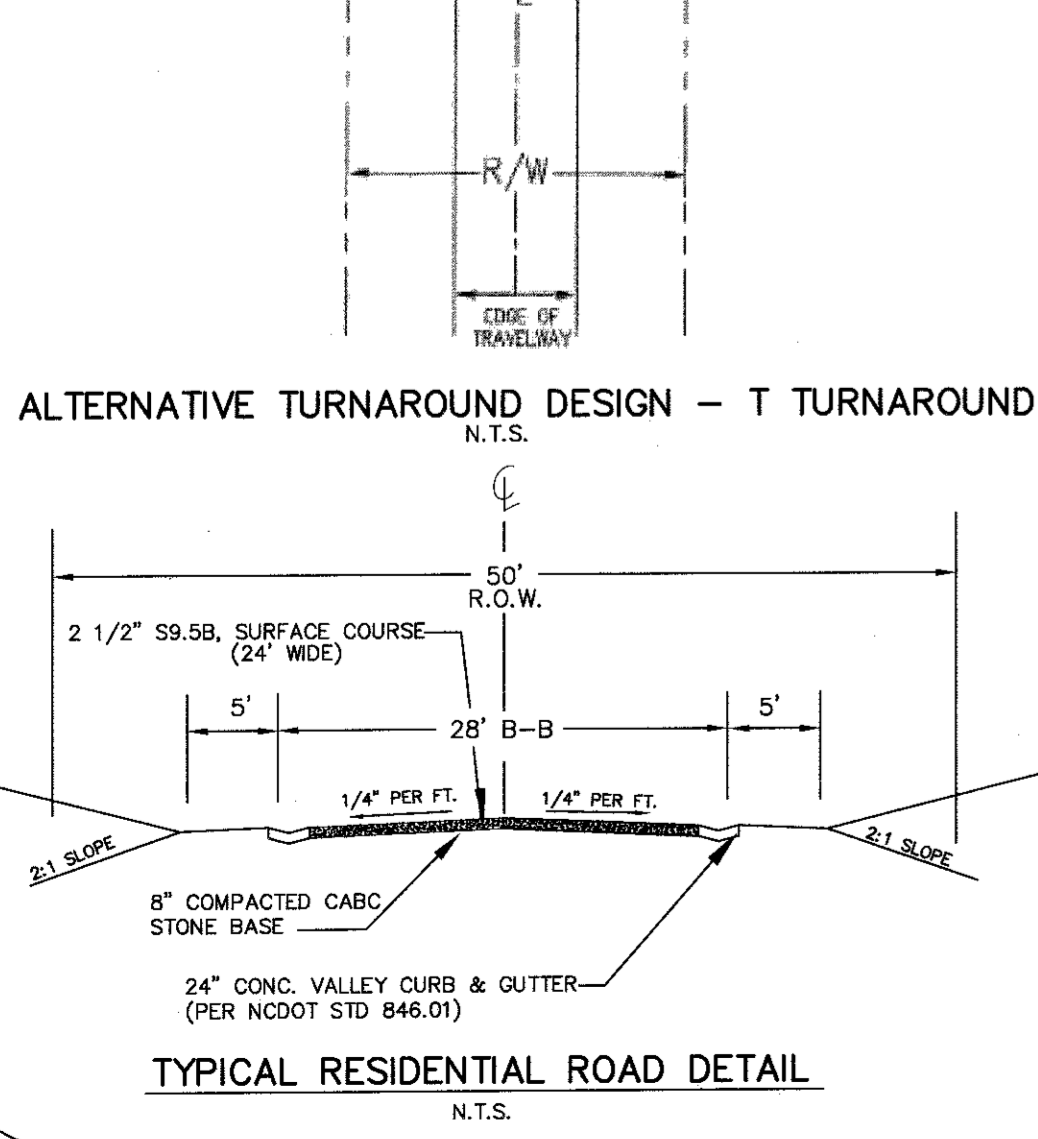
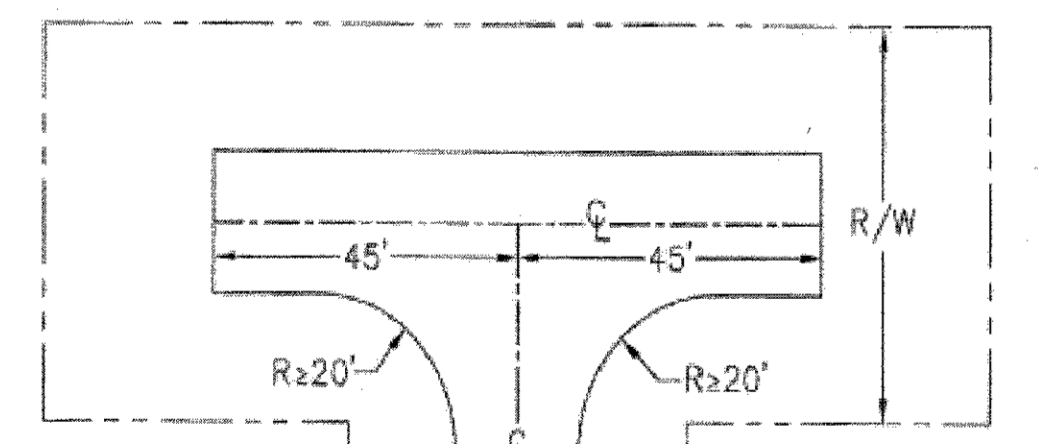

**LEGEND**

	EXISTING SEWER MANHOLE
	EXISTING SEWER LINE
	EXISTING STORM DRAIN LINE
	PROPOSED SEWER MANHOLE
	PROPOSED SEWER LINE
	EXISTING WATER LINE
	PROPOSED WATER MAIN
	PROPOSED FIRE HYDRANT
	PROPOSED GATE VALVE W/BOX
	PROPOSED STORM DRAIN LINE
	PROPOSED DROP INLET

**WGLA Engineering, PLLC**  
Consulting Engineers & Land Planners  
NC License No: P-1342  
84 N. King Street  
Hendersonville, North Carolina 28792  
(828) 687-7177  
wglac.com



**Revisions**

date: 4/16  
job: 16132  
drawn: KHC

F:\USERS\Wj\projects\Windsor Built - Butler Bridge Cottages\16132-C-200.dwg, 5/2/2016 7:05:38 AM, 1:30